

MCS

HYDRAULICS

Raccordi per tubo flessibile - serie Standard
Hose fittings - Standard series
Sae J516 - Iso 12151

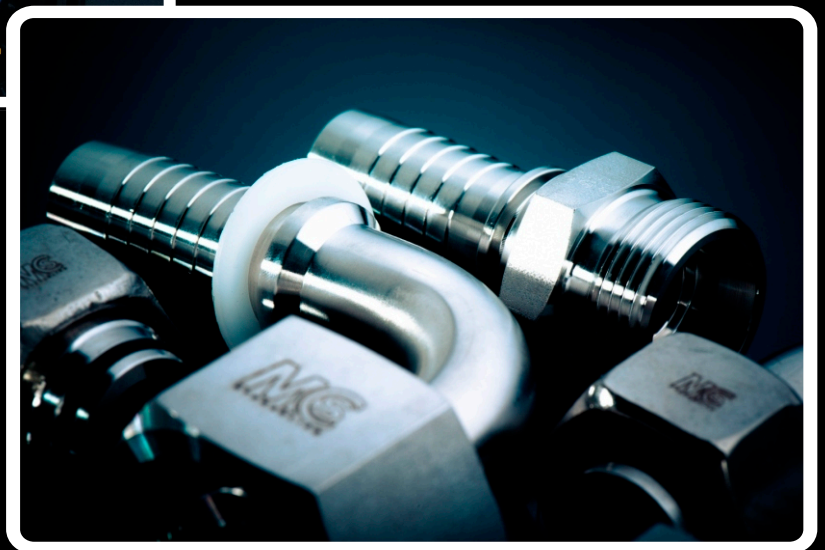
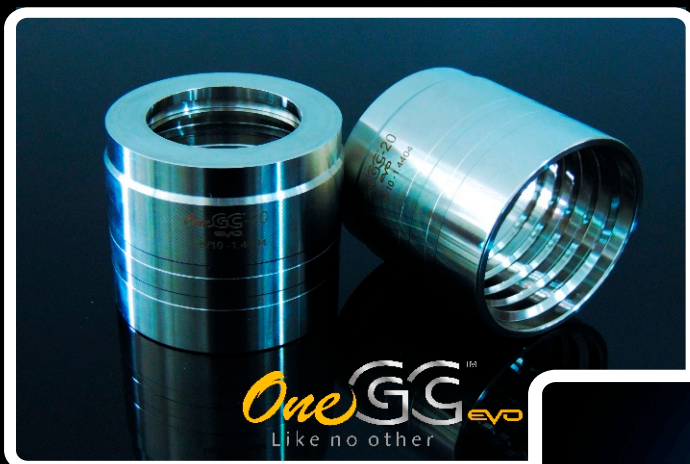

Collezione - Collection
2019

INDICE
INDEX

Pag. 1.1 - 1.5

INFORMAZIONI TECNICHE
TECHNICAL DATA

Pag. 1.6 - 1.27

FEMMINA GIREVOLE GAS CONO 60°
BSP SWIVEL FEMALE 60° CONE



Cod. BSPSF..

Pag. 1.28

FEMMINA GIREVOLE A 45°
GAS CONO 60°
45° BSP SWIVEL FEMALE 60° CONE



Cod. 45BSPSF..

Pag. 1.729

FEMMINA GIREVOLE A 90°
GAS CONO 60°
90° BSP SWIVEL FEMALE 60° CONE



Cod. 90BSPSF..

Pag. 1.30

FEMMINA GIREVOLE O'RING FILETTO
METRICO CONO 24° - SERIE LEGGERA
O'RING METRIC SWIVEL FEMALE
24° CONE - LIGHT TYPE



Cod. ORMSFL..

Pag. 1.31

FEMMINA GIREVOLE O'RING FILETTO
METRICO CONO 24° - SERIE PESANTE
O'RING METRIC SWIVEL FEMALE
24° CONE - HEAVY TYPE



Cod. ORMSFH..

Pag. 1.32

FEMMINA GIREVOLE 45°
O'RING FILETTO METRICO
CONO 24° - SERIE LEGGERA
45° O'RING METRIC SWIVEL
FEMALE 24° CONE - LIGHT TYPE



Cod. 45ORMSFL..

Pag. 1.33

FEMMINA GIREVOLE 45°
O'RING FILETTO METRICO
CONO 24° - SERIE PESANTE
45° O'RING METRIC SWIVEL
FEMALE 24° CONE - HEAVY TYPE



Cod. 45ORMSFH..

Pag. 1.34

FEMMINA GIREVOLE 90°
O'RING FILETTO METRICO
CONO 24° - SERIE LEGGERA
90° O'RING METRIC SWIVEL
FEMALE 24° CONE - LIGHT TYPE



Cod. 90ORMSFL..

Pag. 1.35

FEMMINA GIREVOLE 90°
O'RING FILETTO METRICO
CONO 24° - SERIE PESANTE
90° O'RING METRIC SWIVEL
FEMALE 24° CONE - HEAVY TYPE



Cod. 90ORMSFH..

Pag. 1.36

FEMMINA METRICA OGIVA 24°/60°
METRIC FEMALE 24°/60°
LIGHT MULTISEAL



Cod. MSFLMS..

Pag. 1.37

FEMMINA 90° METRICA OGIVA 24°/60°
90° METRIC FEMALE 24°/60°
LIGHT MULTISEAL



Cod. 90MSFLMS..

Pag. 1.38

FEMMINA METRICA CONO 60°
METRIC FEMALE 60° CONE



Cod. MSFL..

Pag. 1.39

FEMMINA METRICA A 90° CONO 60°
90° METRIC FEMALE 60° CONE



Cod. 90MSFL..

Pag. 1.40

FEMMINA GIREVOLE JIC SV. 74°
JIC SWIVEL FEMALE 74° CONE



Cod. JSF..

Pag. 1.41

FEMMINA GIREVOLE 45° JIC SV. 74°
45° JIC SWIVEL FEMALE 74° CONE



Cod. 45JSF..

Pag. 1.42

FEMMINA GIREVOLE 90° JIC SV. 74°
90° JIC SWIVEL FEMALE 74° CONE



Cod. 90JSF..

Pag. 1.43

FEMMINA GIREVOLE JIC SV. 74°
DOPPIO ESAGONO
JIC SWIVEL FEMALE 74° CONE
DOUBLE HEXAGON
FEMMINA GIREVOLE 60° JIS TOYOTA
JIS SWIVEL FEMALE 60° CONE TOYOTA



Cod. JSFDH..
Cod. JIST..

Pag. 1.44

FEMMINA GIREVOLE GAS SEDE PIANA
BSP SWIVEL FEMALE FLAT SEAT



Cod. BSPSFFS..

Pag. 1.45

FEMMINA GIREVOLE 90° GAS
SEDE PIANA
90° BSP SWIVEL FEMALE FLAT SEAT



Cod. 90BSPSFFS..

Pag. 1.46

FEMMINA GIREVOLE NPSM CONO 60°
NPSM SWIVEL FEMALE 60° CONE
FEMMINA GIREVOLE 90° NPSM CONO 60°
90° NPSM SWIVEL FEMALE 60° CONE



Cod. NPSMSF..
Cod. 90NPSMSF..

Pag. 1.47

FEMMINA GIR.90° GAS - Compatta
BSP SWIVEL FEMALE - Compact Elbow
FEMMINA GIR.90° JIC - Compatta
JIC SWIVEL FEMALE - Compact Elbow

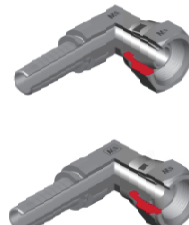

Cod. 90BSPSF..C
Cod. 90JSF..C

Pag. 1.48

FEMMINA METRICA TUBOLARE -
SERIE LEGGERA/PESANTE
METRIC STANDPIPE -
LIGHT/HEAVY TYPE



Cod. SLH.. - SH.. - SL..

Pag. 1.49

FEMMINA METRICA TUBOLARE 45° -
SERIE LEGGERA/PESANTE
45° METRIC STANDPIPE -
LIGHT/HEAVY TYPE



Cod. 45SLH.. - 45SH.. - 45SL..

Pag. 1.50



**FEMMINA METRICA TUBOLARE 90° -
SERIE LEGGERA/PESANTE**
90° METRIC STANDPIPE -
LIGHT/HEAVY TYPE

Cod. 90SLH.. - 90SH.. - 90SL..

Pag. 1.51



**FEMMINA TUBOLARE
(PER TUBO IN POLLICI)**
IMPERIAL STANDPIPE

Cod. IS..

Pag. 1.52



**FEMMINA TUBOLARE
DOPIA ESTREMITÀ**
DOUBLE HOSE STANDPIPE

Cod. DHS..

Pag. 1.53



**FEMMINA PER IDROPULITRICI
K' FEMALE**

Cod. KF..

Pag. 1.54



MASCHIO SVASATO A 60°
Filetto Gas Cilindrico
MALE 60° CONE
Thread BSP Parallel

Cod. BSPM..

Pag. 1.55

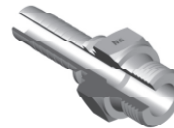

MASCHIO SEDE PIANA
Filetto Gas Cilindrico
MALE FLAT SEAT
Thread BSP Parallel

Cod. BSPMFS..

Pag. 1.56



**MASCHIO METRICO SV. 24° -
SERIE LEGGERA**
METRIC MALE 24° CONE - LIGHT TYPE

Cod. MML..

Pag. 1.57



**MASCHIO METRICO SV. 24° -
SERIE PESANTE**
METRIC MALE 24° CONE - HEAVY TYPE

Cod. MMH..

Pag. 1.58



MASCHIO SVASATO 60°
Filetto Gas Conico
MALE 60° CONE
Thread BSP taper

Cod. BSPTM..

Pag. 1.59



MASCHIO SVASATO 60°
Filetto NPT
MALE 60° CONE
Thread NPT

Cod. NPTM..

Pag. 1.60



MASCHIO JIC CONO 74°
JIC MALE 74° CONE

Cod. JM..

Pag. 1.61

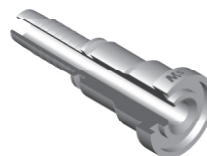

FLANGIA SAE SERIE 3000 PSI
SAE STRAIGHT FLANGE 3000 PSI

Cod. SSF3000..

Pag. 1.62

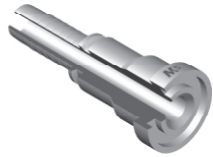

FLANGIA SAE SERIE 6000 PSI
SAE STRAIGHT FLANGE 6000 PSI

Cod. SSF6000..

Pag. 1.63



FLANGIA 45° SAE SERIE 3000 PSI
45° SAE FLANGE 3000 PSI

Cod. 45SF3000..

Pag. 1.64



FLANGIA 45° SAE SERIE 6000 PSI
45° SAE FLANGE 6000 PSI

Cod. 45SF6000..

Pag. 1.65



FLANGIA 90° SAE SERIE 3000 PSI
90° SAE FLANGE 3000 PSI

Cod. 90SF3000..

Pag. 1.66



FLANGIA 90° SAE SERIE 6000 PSI
90° SAE FLANGE 6000 PSI

Cod. 90SF6000..

Pag. 1.67



SEMI FLANGIA TAGLIATA SAE 3000
SPLIT FLANGE SAE 3000 - CUT

Cod. SF3000..

Pag. 1.68



SEMI FLANGIA TAGLIATA SAE 6000
SPLIT FLANGE SAE 6000 - CUT

Cod. SF6000..

Pag. 1.69

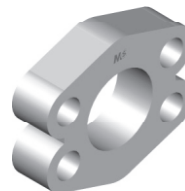

SEMI FLANGIA INTERA SAE 3000
SPLIT FLANGE SAE 3000 - UNCUT

Cod. USF3000..

Pag. 1.70

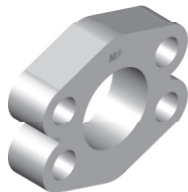

SEMI FLANGIA INTERA SAE 6000
SPLIT FLANGE SAE 6000 - UNCUT

Cod. USF6000..

Pag. 1.71



OCCHIO GAS
BSP BANJO

Cod. BSPBJ..

Pag. 1.72



OCCHIO METRICO
METRIC BANJO

Cod. MBJ..

Pag. 1.73



VITE CAVA PER OCCHIO GAS
BSP BOLT FOR BANJO

Cod. BSPBLT..

Pag. 1.74



VITE CAVA PER OCCHIO METRICO
METRIC BOLT FOR BANJO

Cod. MBLT..

Pag. 1.75



VITE CAVA DOPPIA PER OCCHIO GAS
DOUBLE BSP BOLT FOR BANJO

Cod. DBSPBLT..

Pag. 1.76



FEMMINA ORFS
ORFS FEMALE

Cod. ORFSF..

Pag. 1.77



FEMMINA 45° ORFS
45° ORFS FEMALE

Cod. 45ORFSF..

Pag. 1.78



FEMMINA 90° ORFS
90° ORFS FEMALE

Cod. 90ORFSF..

Pag. 1.79

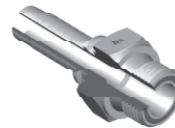

MASCHIO ORFS
ORFS MALE

Cod. ORFSM..

Pag. 1.80



GHIERA R1 PER TUBO:
R1 FERRULE FOR HOSE:
SAE 100 R1AT (EN 853 1SN) -
SAE 100 R1A - EN 857 1SC -
EN 854 2TE HOSE TYPE

Cod. FR1..

Pag. 1.81



GHIERA *ONEGC^{Evo}* PER TUBO:
ONEGC^{Evo} FERRULE FOR HOSE:

Cod. ONEGC^{Evo}..

Pag. 1.82



GHIERA R7 PER TUBO:
R7 FERRULE FOR HOSE:
SAE 100 R6 (EN 854 1TE) -
SAE 100 R7 (EN 855 R7) -
SAE 100 R8 (EN 855 R8) - HOSE TYPE

Cod. FR7..

Pag. 1.83



GHIERA R3 PER TUBO SAE 100 R3
(EN 854 R3)- EN 854 3TE
R3 FERRULE FOR SAE 100 R3
(EN 854 R3)-EN 854 3TE HOSE

Cod. FR3TE..

Pag. 1.84



GHIERA PER TUBO TEFLON LISCIO
FERRULE FOR SMOOTH PTFE HOSE

Cod. FRTE..

Pag. 1.85



GHIERA PER TUBO
TEFLON CORRUGATO
FERRULE FOR CONVULATED
PTFE HOSE

Cod. FRTE^C..

Pag. 1.86

INFORMAZIONI TECNICHE TECHNICAL DATA

BRITISH STANDARDS - STANDARD BRITANNICI

British Standard Pipe Parallel (BSPP)

La filettatura tipo "British Standard Pipe Parallel" è conosciuta in Inghilterra con il nome di "Whitworth".

I maschi BSPP si accoppiano solo con femmine BSPP o attacchi macchina femmina.

I maschi BSPP hanno filettatura cilindrica e svasatura a 30°. Le femmine BSPP hanno filettatura cilindrica e ogiva a 30°.

Gli attacchi macchina femmina hanno filettatura cilindrica e lamatura. La tenuta sull'attacco macchina si ottiene mediante un O'Ring o una rondella di metallo tenero sul maschio.

BSPP males have cylindrical thread and 30° countersink; This thread is also known as "Whitworth".

BSPP males only couple BSPP females. BSPP females have cylindrical thread and 30° cone.

Sealing to fixed devices can be ensured by placing an O'Ring or a deformable metal washer.

COPPIE DI SERRAGGIO - Torque wrench Raccordi BSP SV.60° - Metrico Cilindrico

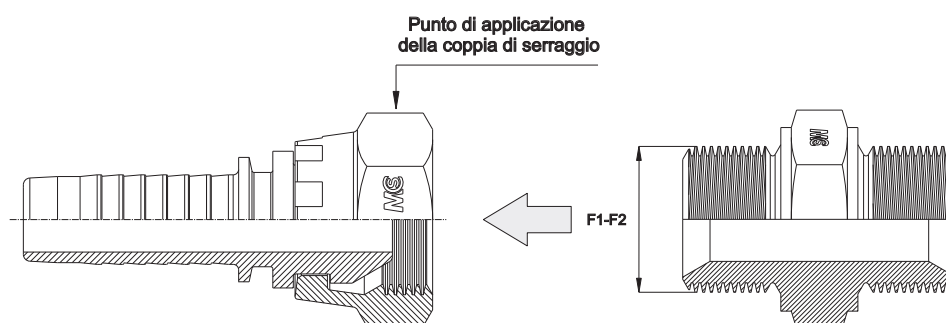

F1	N MAX (Nm)	F2	N MAX (Nm)	TUBO
1/8"	14	10x1	14	6
1/4"	20	12x1,5	20	8
3/8"	35	14x1,5	35	10
1/2"	60	16x1,5	60	12
5/8"	70	18x1,5	70	16
3/4"	110	22x1,5	110	18
1"	140	27x1,5	170	25
1" 1/4	190	33x2	290	32
1" 1/2	290	42x2	310	38

F1 - Filetto Gas Cilindrico - Thread BSP Parallel

F2 - Filetto Metrico Cilindrico - Thread Metric Parallel

USA STANDARDS - STANDARD AMERICANI

SAE J514 37° (JIC)

In applicazioni idrauliche ad alta pressione, la Society of Automotive Engineers (SAE) raccomanda l'utilizzo di un'ogiva a 37° o di una svasatura a 37°, comunemente conosciuti come JIC.

I maschi JIC con ogiva a 37° si accoppiano solo con femmine JIC. I maschi JIC hanno filettatura cilindrica ed un'ogiva a 37°. Le femmine JIC hanno filettatura cilindrica ed una svasatura a 37°. La tenuta avviene sulla sede a 37°, creando una linea di contatto tra l'ogiva del maschio e la svasatura della femmina. La connessione avviene meccanicamente.

For hydraulic high pressure applications, the Society of Automotive Engineers (SAE) recommends to use a 37° cone or countersink, commonly known as JIC. Jic males only couple jic females.

Jic males are characterized by a cylindrical thread and a 37°

Cone and Jic females by a cylindrical thread and a 37° Countersink.

Coupling and sealing are obtained mechanically by a perfect adhesion between the male cone and the female countersink.

COPPIE DI SERRAGGIO - Torque wrench

Raccordi JIC SAEJ514

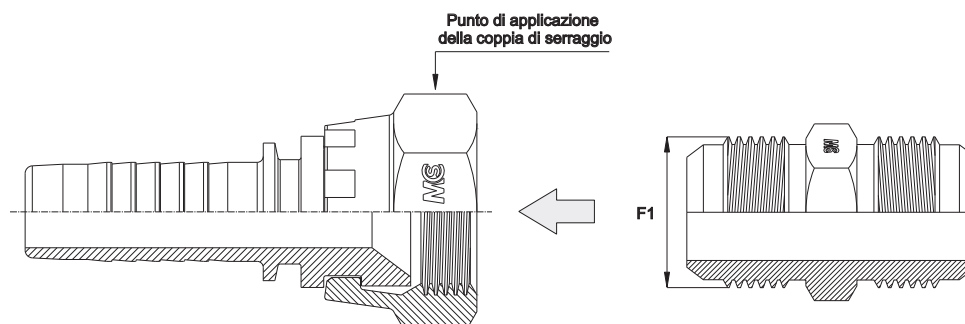

F1/F2	N MIN/MAX (NM)	TUBO
7/16"	15/16	6 - 1/4"
1/2"	19/21	8 - 5/16"
9/16"	24/28	10 - 3/8"
3/4"	49/50	12 - 1/2"
7/8"	77/85	14 - 15 - 16 - 5/8"
1" 1/16	107/119	18 - 20 - 3/4"
1" 5/16	147/154	25 - 1"
1" 5/8	172/181	30 - 32 - 1" 1/4
1" 7/8	215/226	38 - 1" 1/2

USA STANDARDS - STANDARD AMERICANI

SAE J1453 O'Ring Face Seal (ORFS)

In questo tipo di connessioni, la tenuta avviene quando l'O'Ring montato sul maschio va a contatto con la superficie piatta della femmina. Questo tipo di raccordi viene utilizzato nei sistemi idraulici dove è possibile montare un elastomero per evitare le perdite, e dove è indispensabile la resistenza ad eventuali perdite. Ad oggi, contro eventuali trasudazioni e/o perdite, questo tipo di raccordo risulta essere il più efficace. I raccordi maschio e femmina hanno filettatura cilindrica e faccia piana lavorata con macchine a cnc. La tenuta avviene spingendo l'O'Ring contro la faccia piana della femmina. La connessione è mantenuta dai filetti meccanicamente.

These fittings are used for hydraulic systems where a perfect Sealing has to be guaranteed in order to avoid Possible fluid leakage. To this day, these fittings are considered the best Choice for this purpose. Both male and female fittings are characterized by A cylindrical thread and a flat face, sealing is ensured by Placing an O'Ring on male's flat face.

COPPIE DI SERRAGGIO - Torque wrench

Raccordi ORFS SAEJ1453

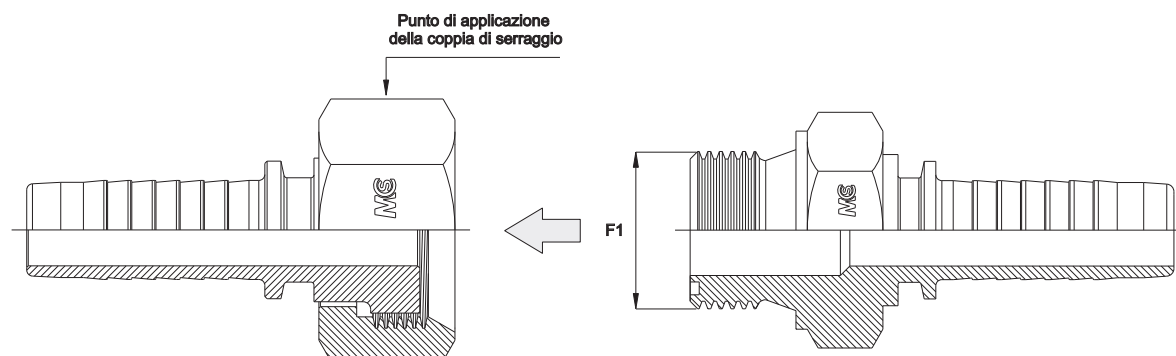

F1	N MIN/MAX (NM)
9/16"	16
11/16"	27
13/16"	47
1"	68
1"3/16	95
1"7/16	135
1"11/16	225
2"	172/181

GERMAN STANDARDS - STANDARD TEDESCHI

DIN 2353 CONO 24°

I maschi DIN 2353 si accoppiano con uno qualsiasi dei tre raccordi femmina mostrati in tabella.

I maschi hanno sede a 24°, filettatura metrica cilindrica ed una lamatura che si accoppia con il DE del tubo. Le femmine possono essere o con sede svasata a 24° con O' Ring (tipo DKO), o un adattatore metrico, o un raccordo universale svasato a 24° o 60°.

Esistono raccordi DIN serie pesante e serie leggera. Per identificarli, è necessario misurare sia la filettatura che il DE del tubo.

Din 2353 males couple any of three female couplings Shown in the table aside.

Males have a cylindrical metric thread, a 24° countersink And a counterbore that couple the tube OD.

Females can have a 24° cone with an o' ring placed on it, or An universal 24/60° cone.

Din Couplings can be light or heavy type, to identify them You have to measure both thread and tube OD.

COPPIE DI SERRAGGIO - Torque wrench

Raccordi DIN 2353

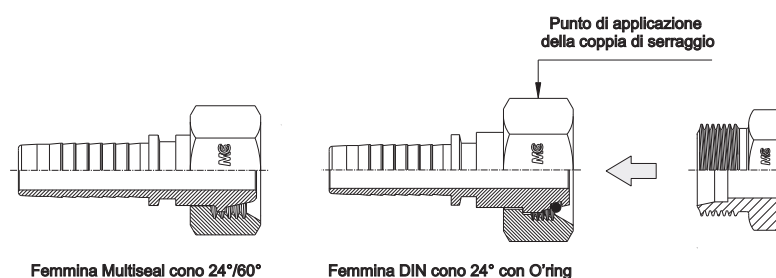

Serie	Tubo	Filetto Metrico	Manuale Inox (Nm)
Series	Tube	Metric Thread	Manual Stainless (Nm)
L	6	12x1,5	30
	8	14x1,5	55
	10	16x1,5	85
	12	18x1,5	120
	15	22x1,5	130
	18	26x1,5	220
	22	30x2,0	320
	28	36x2,0	500
	35	45x2,0	970
	42	52x2,0	1110
S	6	14x1,5	45
	8	16x1,5	55
	10	18x1,5	90
	12	20x1,5	105
	14	22x1,5	150
	16	24x1,5	180
	20	30x2,0	340
	25	36x2,0	530
	30	42x2,0	610
	38	52x2,0	850

GERMAN STANDARDS - STANDARD TEDESCHI

TUBO LISCIO METRICO

I tubi lisci metrici sono composti da tre parti attaccate ad un raccordo maschio, e sono: un tubo liscio, un anello tagliente ed un dado metrico. Il dado è posto sopra il tubo liscio, seguito dall'anello (vedere figura). Per i raccordi DIN serie leggera, si utilizza dado metrico DIN serie leggera; per i raccordi serie pesante, si utilizza invece dado metrico DIN serie pesante.

Metric standpipes consist of three elements connected To a male coupling: a standpipe, a cutting ring and a metric nut. The nut is placed on the standpipe followed by the cutting Ring (see picture).

COPPIE DI SERRAGGIO - Torque wrench Raccordi Tubo Liscio Metrico

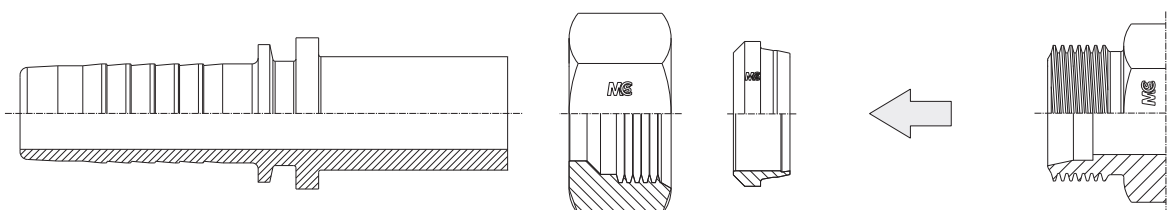

Serie	Tubo	Filetto Metrico	Manuale Inox (Nm)	Macchina Inox (Bar)
Series	Tube	Metric Thread	Manual Stainless (Nm)	Machine Stainless (Bar)
L	6	12x1,5	30	20
	8	14x1,5	55	30
	10	16x1,5	85	35
	12	18x1,5	120	35
	15	22x1,5	130	40
	18	26x1,5	220	60
	22	30x2,0	320	70
	28	36x2,0	500	80
	35	45x2,0	970	100
	42	52x2,0	1110	160
S	6	14x1,5	45	20
	8	16x1,5	55	30
	10	18x1,5	90	35
	12	20x1,5	105	35
	14	22x1,5	150	40
	16	24x1,5	180	55
	20	30x2,0	340	80
	25	36x2,0	530	105
	30	42x2,0	610	130
	38	52x2,0	850	160

PRESSIONE MASSIMA DI ESERCIZIO DEI RACCORDI (BAR)

HOSE FITTINGS MAXIMUM WORKING PRESSURE

Normativa di riferimento	Filetto dei raccordi in pollici										
	1/8"	1/4"	5/16"	3/8"	1/2"	5/8"	3/4"	1"	1 1/4"	1 1/2"	2"
BSP 60° femmina	350	630	-	550	430	-	350	280	250	210	210
BSP 60° maschio	350	630	-	550	430	-	350	280	250	210	210
JIC 37° femmina	-	410	410	345	345	345	345	275	200	170	170
JIC 37° maschio	-	410	410	345	345	345	345	275	200	170	170
JIS 60° femmina	-	350	350	350	350	-	280	210	175	-	-
JIS 60° maschio	-	350	-	350	350	-	280	210	175	-	-
JIS 30° femmina	-	350	350	350	350	280	280	210	175	-	-
KOMATSU 30° metrico	-	350	350	350	350	350	280	210	175	-	-
NPTF maschio	345	345	-	275	240	-	210	170	150	140	140
ORFS femmina	-	410	-	410	410	410	410	275	275	-	-
ORFS maschio	-	410	-	410	410	410	410	275	275	-	-
SAE 45° femmina	-	410	410	345	345	345	345	275	200	170	170
SAE 45° maschio	-	410	410	345	345	345	345	275	200	170	170
SAE 3000 flangia	-	-	-	-	345	345	345	345	275	210	210
SAE 6000 flangia	-	-	-	-	-	-	410	410	410	410	410
SAE maschio	-	410	410	345	345	345	345	275	200	170	170

Normativa di riferimento	Serie metrica leggera (mm.)										
	6	8	10	12	15	18	22	28	35	42	
DIN 24° femmina	250	250	250	250	250	160	160	100	100	100	
DIN 24° femmina con o' ring	250	250	250	250	250	160	160	100	100	100	
DIN 24° maschio	250	250	250	250	250	160	160	100	100	100	
Codolo metrico	Per i progetti di nuova generazione è sconsigliato usare questo tipo di raccordo										

Normativa di riferimento	Serie metrica pesante (mm.)										
	8	10	12	14	16	20	25	30	38		
DIN 24° femmina	630	630	630	630	400	400	400	250	250		
DIN 24° femmina con o' ring	630	630	630	630	400	400	400	250	250		
DIN 24° maschio	630	630	630	630	400	400	400	250	250		
Codolo metrico	Per i progetti di nuova generazione è sconsigliato usare questo tipo di raccordo										

COME STABILIRE IL TIPO DI FILETTO TRAMITE L'UTILIZZO DEL CALIBRO. HOW TO IDENTIFY THREADS BY USING A CALIPER.

Misurando con il calibro il diametro interno di una femmina, oppure il diametro esterno della filettatura di un maschio, si ricaverà una quota in mm. Mediante questo valore, guardando la sottostante tabella, si potrà determinare il tipo di filettatura corrispondente.

By measuring a female internal diameter or a male outer diameter with a calliper, you will easily determine which thread it is, Checking the following table



type	thread	dash size	male mm	female mm	type	thread	dash size	male mm	female mm
BSP	$1/8$	02	9,6	8,7	JIC	$1 1/16$	12	26,8	24,8
JIC	$7/16$	04	11	9,9	Metric	M30-2	30	29,9	28
Metric	M12-1.5	12	11,9	10,5	Metric	M36-1.5	30	29,9	28,5
JIC	$1/2$	05	12,6	11,4	ORFS	$1 3/16$	14	30	28
BSP	$1/4$	04	13	11,6	JIC	$1 3/16$	14	30,1	27,9
Metric	M14-1.5	14	13,9	12,5	Metric	M33-1.5	33	32,9	31,5
JIC	$9/16$	06	14,2	12,9	BSP	1	16	33,1	30,7
ORFS	$9/16$	06	14,2	12,9	JIC	$1 5/16$	16	33,2	31,2
JIC	$5/8$	07	15,7	14,5	Metric	M36-2	36	35,9	34
Metric	M16-1.5	16	15,9	14,5	Metric	M36-1.5	36	35,9	34,5
BSP	$3/8$	06	16,6	15,1	ORFS	$1 7/16$	15	36,4	34,4
ORFS	$11/16$	09	17,4	15,9	Metric	M38-1.5	38	37,9	36,5
Metric	M18-1.5	18	17,9	16,5	JIC	$1 5/8$	20	41,1	38,8
JIC	$3/4$	08	18,8	17,5	BSP	$1 1/4$	20	41,7	39,4
Metric	M20-1.5	20	19,9	18,5	Metric	M42-2	42	41,9	40
ORFS	$13/16$	11	20,6	19,1	ORFS	$1 11/16$	21	42,7	40,7
BSP	$1/2$	08	20,8	18,8	Metric	M45-2	45	44,9	43
Metric	M22-1.5	22	21,9	20,5	Metric	M45-1.5	45	44,9	43,5
JIC	$7/8$	10	22,1	20,4	JIC	$1 7/8$	24	47,5	45,1
BSP	$5/8$	10	22,8	20,9	BSP	$1 1/2$	24	47,7	45,2
Metric	M24-1.5	24	23,9	22,5	Metric	M52-2	52	51,9	50
ORFS	1	13	25,3	23,6	BSP	2	32	59,4	57,4
Metric	M26-1.5	26	25,9	24,5	JIC	$2 1/2$	32	63,3	61,1
BSP	$3/4$	12	26,3	24,5	ORFS	$2 1/2$	32	63,4	61,4

SCelta DELLA DIMENSIONE DEL TUBO FLESSIBILE

Utilizzando il grafico sottostante si può determinare la dimensione del tubo flessibile in funzione della portata e della velocità del fluido.

Per trovare la dimensione di tubo desiderato basta unire con una retta i valori noti della portata e della velocità. L'intersezione della retta così tracciata determina sul grafico centrale il valore del diametro di tubo da scegliere. Nel caso in cui il valore trovato non si trovi in corrispondenza di uno dei diametri DN indicati scegliere il valore superiore.

CHOICE OF HOSE SIZE

The graphic below can be used for the correct choice of the rubber hose. It allows to calculate the hose dimension according to the flow value and the speed of the fluid.

To find out the dimension of the right hose, draw a straight line connecting the known values of flow and speed. The intersection of this line with the graphic in the middle of the picture determines the value of the diameter of the hose. In case the value found is not corresponding with one of the nominal diameters DN indicated, the largest value must be chosen.

Velocità consigliate:

Linee di pressione/pressure lines : 3 - 8 m/s

Linee di ritorno/return lines : 1,5 - 3 m/s

Linee di aspirazione/suction lines : 0,5 - 1,5 m/s

Linee di pilotaggio/pilot lines : max 5 m/s

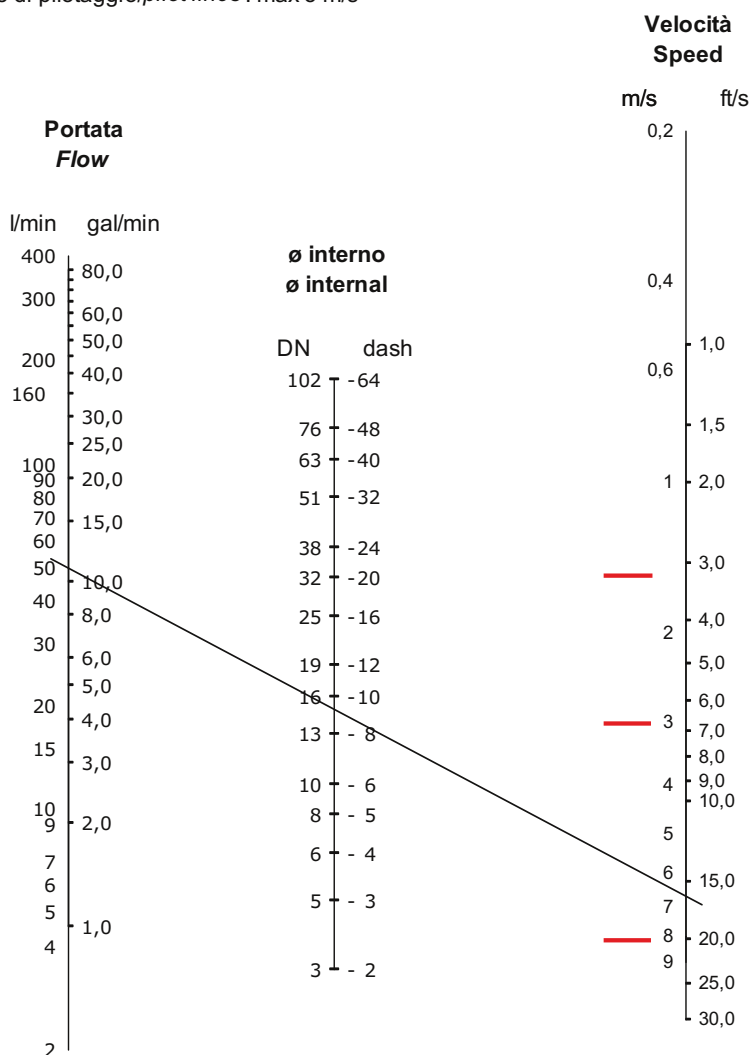

LUNGHEZZA E ORIENTAMENTO DEI TUBI FLESSIBILI ASSEMBLATI

La lunghezza di un tubo flessibile assemblato con raccordi dritti maschio si misura alle estremità delle due connessioni. Per i raccordi femmina la lunghezza viene misurata all'estremità delle tenute coniche o sulle superfici piane di tenuta. Nel caso in cui entrambi i raccordi siano occhielli oppure curve, è necessario determinare l'angolo di orientamento richiesto.

Per trovare la giusta gradazione, bisogna prima pressare i raccordi, e successivamente posizionarli nel seguente modo :

Mettere verticalmente il raccordo più lontano e far ruotare in senso orario il raccordo più vicino.

Far ruotare il raccordo più vicino fino a che le verticali dei raccordi non formano un angolo della gradazione richiesta.

LENGTH AND PLACING OF ASSEMBLED HOSES

Assembled flexible hose length has to be measured between two end fittings; should the hose be mounted with elbows or banjos, it is required to determine orientation angle.

To find the right grade, you need to crimp fittings on hose, then place vertically the outmost fitting spinning clockwise the closest one, until the angle of the vertical between fittings won't be as required.



Tabella delle tolleranze sui tubi flessibili assemblati Normativa DIN 20066		
Lunghezza del tubo assemblato in mm.	Fino a 1"	Oltre 1"
Fino a 630	+7/-3 mm.	+12/-4 mm.
da 631 a 1250	+12/-4 mm.	+20/-6 mm.
da 1251 a 2500	+20/-6 mm.	+25/-6 mm.
da 2501 a 8000	+3% / -1%	+3% / -1%
oltre 8000	+3% / -1%	+3% / -1%

*Assembled hoses tolerances table.

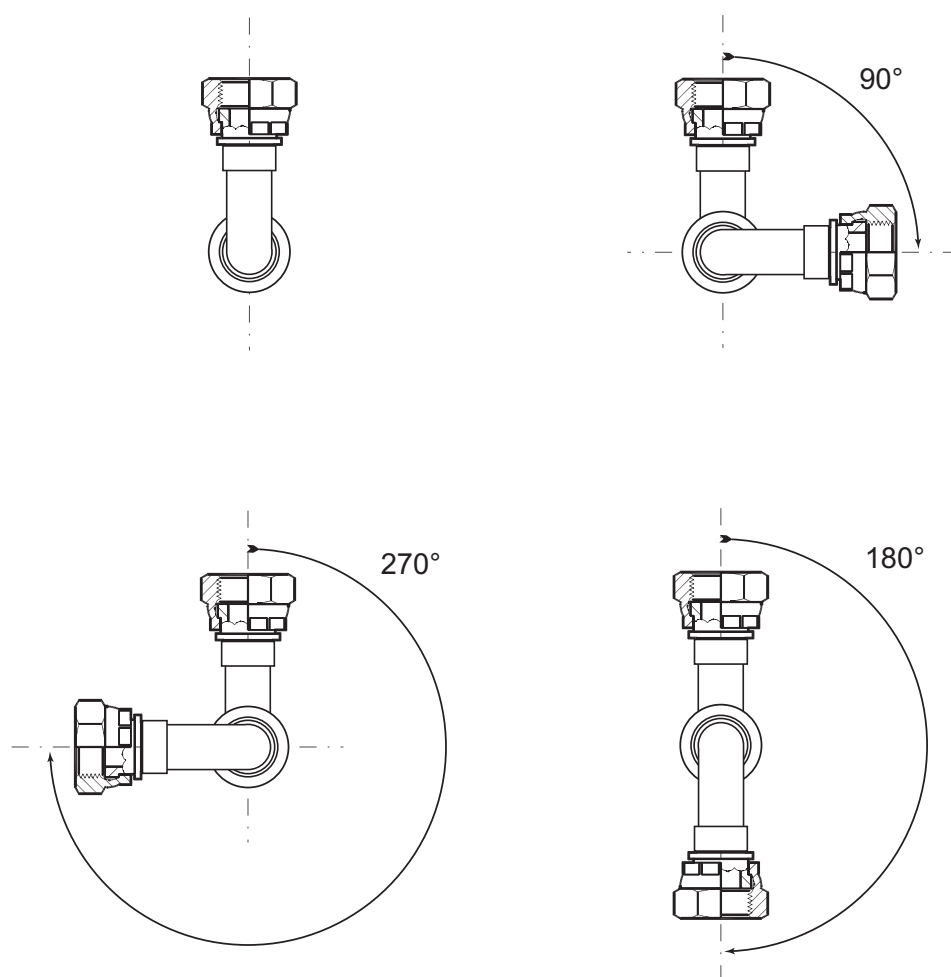
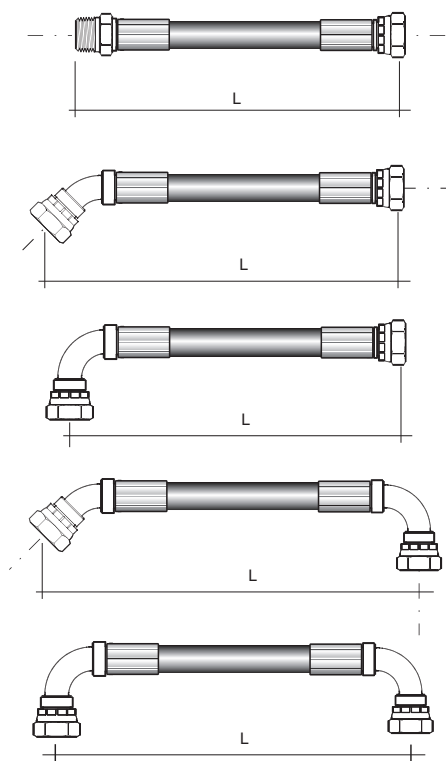

TOLLERANZA GENERALE CUT-OFF E DROP RACCORDI MCS MCS's fittings CUT-OFF and DROP general tolerance

Le misure, i dati tecnici etc. menzionati nei nostri cataloghi sono riportati a titolo puramente informativo. In caso di modifiche o cambiamenti di modelli, non è possibile consegnare articoli con le caratteristiche precedenti.

del proprio processo tecnologico, senza nessun preavviso.

Please be aware that all the technical data provided in our catalogues are for guidance purposes only. Owing to our policy of continual improvement, M.C.S. Hydraulics reserve the right to alter specifications and dimensions without prior notice; in this cases it will not be possible to deliver older versions products.

Tabella delle tolleranze Cut-off & Drop
Cut-off & Drop tolerance table

Fino a 1" up to 1"	Oltre 1" from 1"
+3/-1.5 mm.	+5.5/-2 mm.

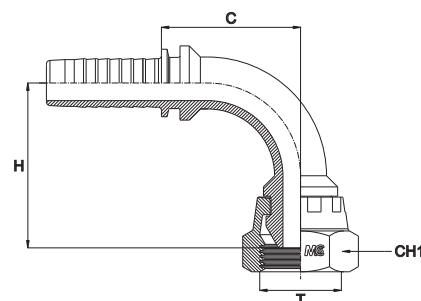

ISTRUZIONI DI MONTAGGIO DEI RACCORDI PER TUBI FLESSIBILI. HOSE FITTINGS ASSEMBLY INSTRUCTIONS

RACCORDI PER TUBI FLESSIBILI NO SKIVE (SENZA PELATURA ESTERNA) - SERIE STANDARD

1. Tagliare il tubo alla lunghezza desiderata e ad angolo retto e eliminare all'imbocco del tubo eventuali residui dovuti al taglio.
2. Inserire la ghiera sul tubo fino al suo arresto.
3. Inserire le "resche" del raccordo nel tubo fino a che lo stesso non arrivi in battuta con la relativa ghiera.
4. Pressare quindi la ghiera sul tubo al diametro di pressatura indicato nella tabella di assemblaggio.

STANDARD FITTINGS FOR NO SKIVE HOSES

1. Cut the hose right angle to required length, remove possible scraps.
2. Place the ferrule onto the hose;
3. Push insert tail to the hose;
4. Crimp the ferrule on the hose at the swaging diameter indicated on our chart.

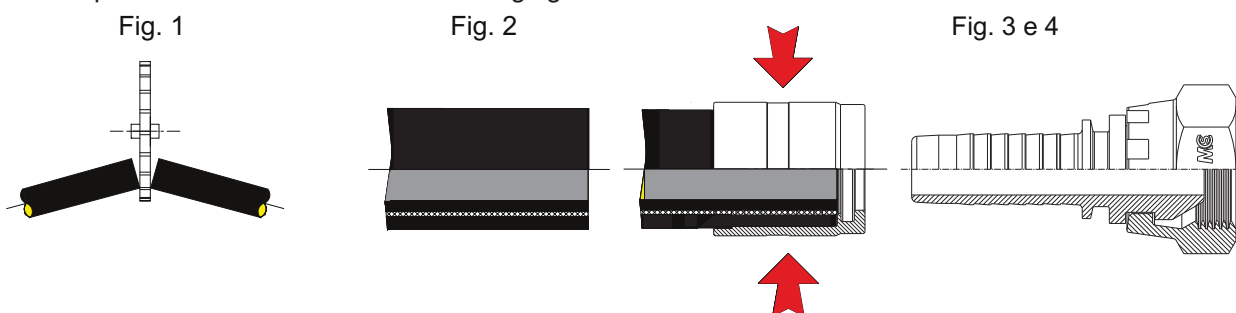

RACCORDI PER TUBI FLESSIBILI SKIVE (CON PELATURA ESTERNA) - SERIE STANDARD

1. Tagliare il tubo alla lunghezza desiderata e ad angolo retto e eliminare all'imbocco del tubo eventuali residui dovuti al taglio.
2. Rimuovere la copertura esterna del tubo per la lunghezza indicata nella tabella di assemblaggio al diametro esterno del rinforzo metallico evitando di danneggiarlo).
3. Inserire la ghiera sul tubo fino al suo arresto.
4. Inserire le "resche" del raccordo nel tubo fino a che lo stesso non arrivi in battuta con la relativa ghiera.
5. Pressare quindi la ghiera sul tubo al diametro di pressatura indicato nella tabella di assemblaggio.

STANDARD FITTINGS FOR SKIVE HOSES

1. Cut the hose right angle to required length, remove possible scraps.
2. Remove the hose outer layer to the skiving length indicated in our chart;
3. Place the ferrule onto the hose;
4. Push insert tail to the hose;
5. Crimp the ferrule on the hose at the swaging diameter indicated on our chart.

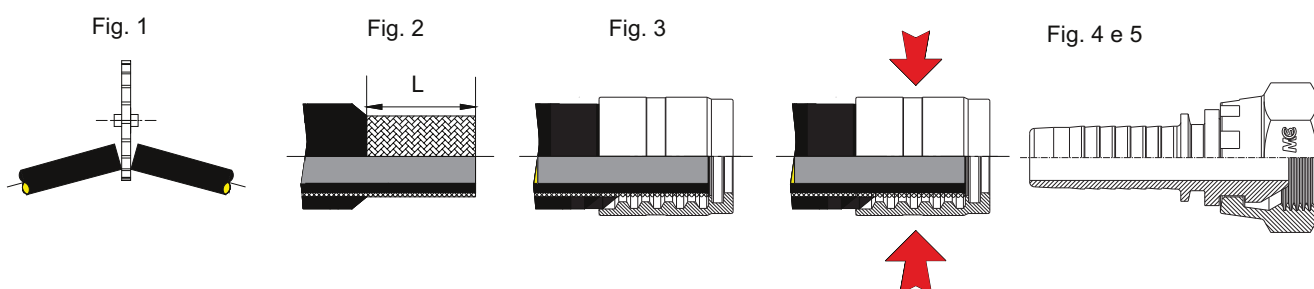

GUIDA ALL'INSTALLAZIONE DEI TUBI FLESSIBILI SECONDO DIN 20066. HOSES INSTALLATION INSTRUCTION ACCORDING TO DIN 20066

Per garantire la sicurezza, la funzionalità e la durata dei tubi flessibili e dei raccordi relativi è indispensabile non superare mai le pressioni di esercizio e le temperature massime ammissibili, montare i tubi nella maniera corretta, utilizzare i raccordi più appropriati in funzione delle condizioni di montaggio e stabilire la lunghezza dei tubi, tenendo ben presente, dove necessario, il movimento dei tubi stessi.

Pertanto rispettare le prescrizioni di seguito specificate per una corretta installazione dei tubi flessibili assemblati :

To guarantee pressed hoses safety, life and feature, it is recommended:

- to respect the maximum temperature and working pressure ;
- to mount them correctly;
- to chose the right fittings with relation to hoses length and installation conditions.

It is strongly recommended to respect the following rules:

Torsione

Non applicare torsioni. È importante accertarsi che non si verifichino situazioni gravose che possano ridurre la normale durata del flessibile e potrebbero causare cedimenti in pressione.

Torsion

Do not apply any torsion.
It may cause serious damage under pression.

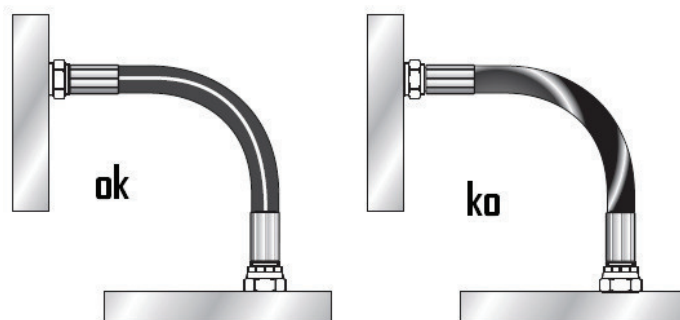

Variazione in lunghezza

Non montare il flessibile troppo in tensione, perché nel tempo e durante i vari movimenti si potrebbero verificare delle variazioni di lunghezza, a volte causa di rottura prematura.

È opportuno calcolare una lunghezza leggermente superiore a quella richiesta; infatti le norme DIN e SAE prevedono che il tubo alla pressione di esercizio possa subire un allungamento (max +2%) o un accorciamento (max -4%).

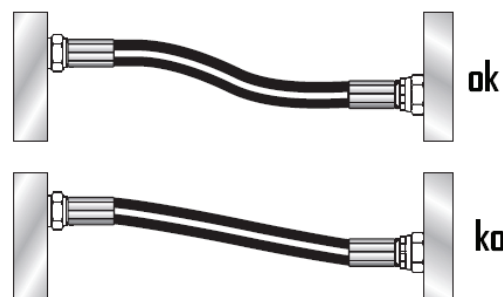

Length variation

Another key factor is hose length, due to hose movements, A wrong length may cause surface wear and pressure Drops.

It is recommended to calculate a length greater than Required; According To Sae and Din standards an hose Under pressure can be extended (max +2%) or shortened (max -4%)



Prima di assemblare bisogna necessariamente ingrassare i componenti con il composto antigrippaggio sintetico, contattare il nostro ufficio tecnico per conoscere i prodotti consigliati

Before assembling, the components need to be lubricated with a Synthetic Anti-seize compound. For further information or advice on products to be used, kindly contact our Technical Department.

Flessibili in movimento

Quando si utilizzano flessibili in movimento fare attenzione ad evitare eventuali torsioni, tensioni o abrasioni che potrebbero risultare dannose per il normale funzionamento dello stesso.

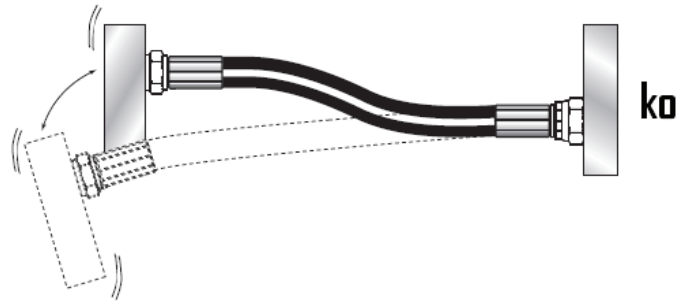

Mobile connections

Connections involving mobile components
Must be carefully determined according to hose movements

Raggio di curvatura

Si raccomanda di rispettare il raggio di curvatura minimo stabilito dal produttore; curve più strette sono fonte di sollecitazioni meccaniche procuranti lesioni critiche alla tessitura metallica; con minore sopportazione alla massima pressione di esercizio, drastica riduzione della pressione di scoppio ed una durata inferiore.



Bending Radius

It is recommended to respect the minimum Bending radius during assembly because bends With a lower radius would result in mechanical Stress and serious damages to metal threads Which would shorten working life, and reduce Burst pressure and resistance to max pressure. Excessive bending would neutralise the advantage Of lower pressure drops in hose bends.

Scelta dei raccordi

Utilizzare raccordi adeguati per evitare sollecitazioni al tubo flessibile.
Eliminare posizioni non corrette che il Flessibile potrebbe assumere una volta Installato sull'impianto.

Choose the right fitting!!

Select the suitable fitting in order
To avoid any stress to crimped hose.



TABELLA COMPATIBILITÀ FLUIDI

Fluids Compatibility table

Fluido	Acciaio Inox	NBR	VITON®	Fluido	Acciaio Inox	NBR	VITON®
Acetilene	O	N	N	Gas Naturale Non Trattato	O	N	N
Acetone	O	N	N	Gasolio	O	O	O
Acido Cloridrico	S	N	O	Glicerina	O	O	O
Acido Fosforico	N	N	S	Glicole	O	O	O
Acido Nitrico	S	N	S	Idrogeno	O	O	O
Acido Solforico	S	N	O	Iodio	O	S	O
Acqua	S	N	O	Kerosene	O	O	O
Acqua Distillata	O	O	O	Metano	O	O	O
Acqua Marina	S	O	O	Metanolo	O	O	O
Acqua Ossigenata	O	N	O	Nafta	O	O	O
Acquaragia	O	O	O	Neon	O	O	O
Ammoniaca Gassosa, Fredda	O	O	N	Olio	O	O	O
Ammoniaca Liquida	O	S	N	Olio da Riscaldamento	O	O	N
Anidride Carbonica	O	O	S	Olio dei Freni	O	N	O
Argo	O	O	O	Olio della Trasmissione	O	O	O
Aria	O	O	O	Olio Minerale	O	O	O
Aria compressa	O	O	O	Olio Minerale Naturale	O	S	O
ASTM-Oil, 1	O	O	O	Olio per Comandi Idraulici	O	O	O
ASTM-Oil, 2	O	O	O	Olio Vegetale	O	O	O
ASTM-Oil, 3	O	O	O	Ossido di Carbonio	O	O	N
Azoto	O	O	O	Ossigeno	O	N	O
Benzene	O	N	O	Ozono	O	N	O
Biossido di Zolfo	O	N	O	Pentano	O	O	O
Bisolfuro di Carbonio	O	N	O	Pentano Liquido	O	O	O
Butano	O	O	O	Propano	O	O	O
Cloro	O	N	O	Silicone	O	O	O
Elio	O	O	O	Stirene	O	S	O
Etano	O	O	N	Toluolo	O	N	S
Etere	O	O	N	Trielina	S	N	S
Gas Combustibile	O	O	S	Vapore	O	N	N
Gas Naturale	O	O	O	Xilolo	O	N	O

Legenda: O = Ottimo; S = Sufficiente; N = Non Raccomandato.

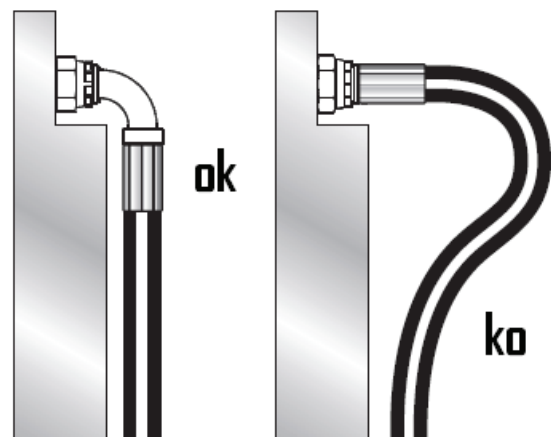
Legend : O = Excellent ; S = Sufficient ; N = Not Recommended

VITON® è un marchio registrato dalla DuPont Dow Elastomers

VITON® is a DuPont Dow Elastomers Trade Mark

SEDI E FILETTATURE BSP THREAD COUPLING - BSP THREAD

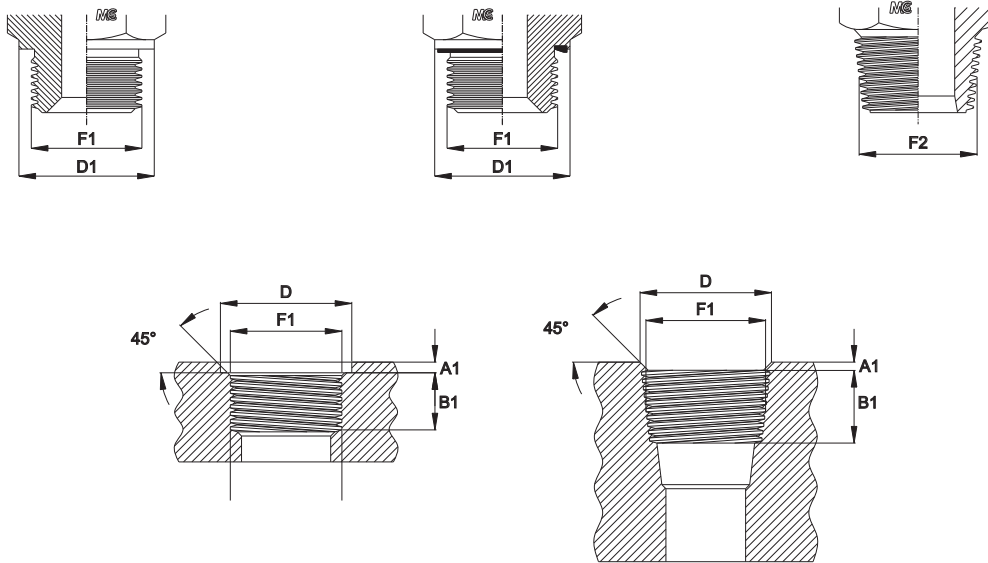

F1	F2	A1 MAX	B1 MIN	D	D1	D2	B2 MIN	TUBO	SERIE
1/8"	1/8"	1	8	15	14	14	5,5	6	L
1/4"	1/4"	1,5	12	19	18	18,9	8,5	8	L
1/4"	1/4"	1,5	12	19	18	18,9	8,5	10	L
3/8"	3/8"	1,5	12	23	22	22	8,5	12	L
1/2"	1/2"	2	12	27	26	26,9	10,5	15	L
1/2"	1/2"	2,5	14	27	26	26,9	10,5	18	L
3/4"	3/4"	2,5	16	33	32	32	13	22	L
1"	1"	2,5	18	40	39	39,9	16	28	L
1" 1/4	1" 1/4	2,5	20	50	49	49,9	17	35	L
1" 1/2	1" 1/2	2,5	22	56	55	55	17	42	L
1/4"	1/4"	1,5	12	19	18	18,9	8,5	6	S
1/4"	1/4"	1,5	12	19	18	18,9	8,5	8	S
3/8"	3/8"	1,5	12	23	22	22	8,5	10	S
3/8"	3/8"	2	12	23	22	22	8,5	12	S
1/2"	1/2"	2	14	27	26	26,9	10,5	14	S
1/2"	1/2"	2,5	14	27	26	26,9	10,5	16	S
3/4"	3/4"	2,5	16	33	32	32	13	20	S
1"	1"	2,5	18	40	39	39,9	16	25	S
1" 1/4	1" 1/4	2,5	20	50	49	49,9	17	30	S
1" 1/2	1" 1/2	2,5	22	56	55	55	17	38	S

F1 - Filetto Gas Cilindrico - Thread BSP Parallel
F2 - Filetto Gas Conico - Thread BSP Taper

SEDI E FILETTATURE METRICHE THREAD COUPLING - METRIC THREAD

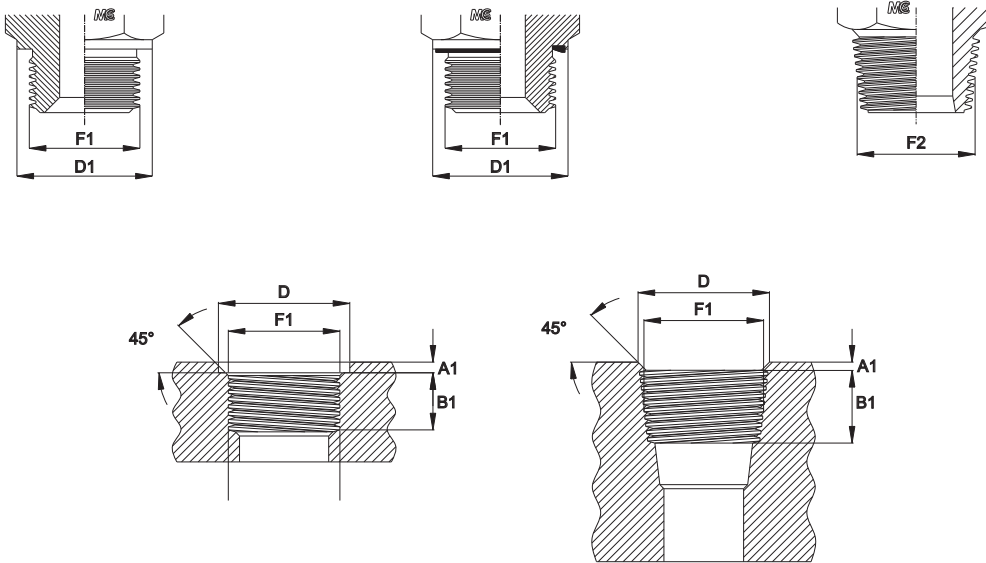

F1	F2	A1 MAX	B1 MIN	D	D1	D2	B2 MIN	TUBO	SERIE
10x1	10x1	1	8	15	14	14	5,5	6	L
12x1,5	12x1,5	1,5	12	18	17	17	8,5	8	L
14x1,5	14x1,5	1,5	12	20	19	19	8,5	10	L
16x1,5	16x1,5	1,5	12	22	21	21,9	8,5	12	L
18x1,5	18x1,5	2	12	24	23	23,9	8,5	15	L
22x1,5	22x1,5	2,5	14	28	27	27	10,5	18	L
26x1,5		2,5	16	32	31	31,9		22	L
33x2		2,5	18	40	39	39,9		28	L
42x2		2,5	20	50	49	49,9		35	L
48x2		2,5	22	56	55	55		42	L
12x1,5	12x1,5	1,5	12	18	17	17	8,5	6	S
14x1,5	14x1,5	1,5	12	20	19	19	8,5	8	S
16x1,5	16x1,5	1,5	12	22	21	21,9	8,5	10	S
18x1,5	18x1,5	2	12	24	23	23,9	8,5	12	S
20x1,5	20x1,5	2	14	26	25	25,9	10,5	14	S
22x1,5	22x1,5	2,5	14	28	27	27	10,5	16	S
27x2		2,5	16	33	32	32		20	S
33x2		2,5	18	40	39	39,9		25	S
42x2		2,5	20	50	49	49,9		30	S
48x2		2,5	22	56	55	55		38	S

F1 - Filetto Metrico Cilindrico - Thread Metric Parallel
F2 - Filetto Metrico Conico - Thread Metric Taper

SEDI E FILETTATURE UNF/UN-2A THREAD COUPLING - UNF/UN-2A

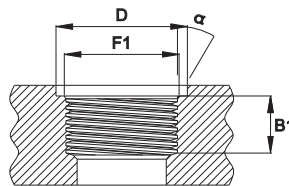
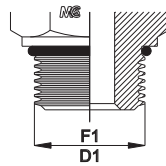

F1	A1 MAX	B1 MIN	D	D1	a
7/16"	1,6	11,5	21	15,8	12°
1/2"	1,6	11,5	23	16,2	12°
9/16"	1,6	12,7	25	17,7	12°
3/4"	2,4	14,3	30	23	15°
7/8"	2,4	16,7	34	27	15°
1" 1/16	2,4	19	41	32	15°
1" 5/16	3,2	19	49	38,1	15°
1" 5/8	3,2	19	58	48	15°

F1 - UNF/UN-2A

SEDI E FILETTATURE NPT THREAD COUPLING - NPT

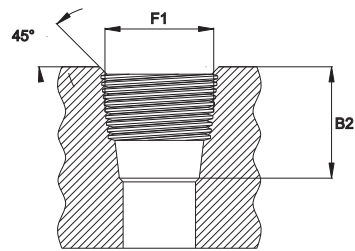
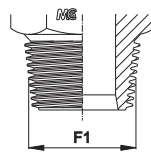

F1	B2 MIN
1/8"	1,6
1/4"	1,6
3/8"	1,6
1/2"	2,4
3/4"	2,4
1"	2,4
1" 1/4	3,2
1" 1/2	3,2

F1 - NPT

GUARNIZIONI IMPIEGATE

Sealing Materials :

Le guarnizioni impiegate, possono essere sia in NBR ed hanno una temperatura di esercizio compresa tra i -35°C ed i 100°C e durezza 85±5 Shore, sia in VITON® se dovessero sostenere temperature di esercizio più elevate comprese tra i -25°C ed i 200°C e durezza 80±5 Shore. Tali prodotti devono essere stoccati secondo la norma DIN 7716 (Requisiti per l'immagazzinamento di prodotti in gomma e caucciù).

Seals used can be in NBR (Nitrile Rubber), so they have an operating temperature from -35°C to 100°C and hardness 85± 5 Shore, and in Viton® in case they are used for highest temperature from -25°C to 200°C and hardness 80±5 Shore. These products must be stored according to DIN 7716 (This is essential for the stocking of rubber products).

TEMPERATURE AMMESSE E RIDUZIONI DI PRESSIONE

Pressure reductions and Temperature

Acciaio inossidabile da -60°C a 200°C secondo ISO 8434.

La riduzione della pressione di esercizio sui raccordi in acciaio inossidabile 1.4571 deve essere applicata in funzione della temperatura di esercizio riscontrata, secondo la NORMA ISO 8434. In caso di sistema con più componenti i parametri devono essere calcolati sul componente più debole.

Stainless steel from -60°C to 200°C according to ISO 8434.

The reduction of the operating pressure on stainless steel fittings 14571 must be applied according to the operating temperature, in accordance with ISO 8434. For systems consisting of more components the parameters must be calculated on the weakest component.

<i>Tipo di acciaio impiegato</i> Type of Steel used	<i>Temperatura di esercizio</i> Operating temperature	<i>Riduzione della pressione di esercizio</i> Oper. Press.Reduc.
1,4571	≥ 50°C	-4%
1,4571	≥100°C	-11%
1,4571	≥200°C	-20%

TRATTAMENTO DI FINITURA

Cleaning Process

Processo di Lavaggio ad Ultrasuoni:

Tutti gli articoli prodotti dalla M.C.S. Hydraulics sono sottoposti ad un trattamento di lavaggio ed asciugatura ad ultrasuoni.

La M.C.S. Hydraulics utilizza un sistema di vasche di lavaggio ad ultrasuoni doppia frequenza con moduli di risciacquo ed asciugatura; le bolle di cavitazione generate dalle onde ultrasoniche, consentono la rimozione di impurità e residui, come polvere, olii, grassi, trucioli e bave di lavorazione che aderiscano alla superficie metallica, senza peraltro intaccare il materiale stesso.

La tecnologia del lavaggio con ultrasuoni è molto diffusa come sistema per la pulizia di gioielleria, nonché di dispositivi medici ed odontoiatrici e viene sempre più spesso utilizzata per il lavaggio industriale: al termine di tale processo il raccordo si presenta brillante, completamente pulito e sterilizzato e soprattutto si presta ad essere utilizzato per svariate applicazioni particolari.

Ultrasonic Cleaning:

Each item produced by M.C.S. Hydraulics is subjected to an ultrasonic cleaning treatment. M.C.S. employs a cleaning device that uses Ultrasonic dual frequency waves and an appropriate cleaning solvent, to clean each and every product.

Cavitation bubbles induced by the Ultrasound waves, act on a number of contaminants (Such as dirt, dust, grease etc.) adhering to metal.

This action also penetrates blind holes, cracks, and recesses; the intention is to remove all traces of contamination from surface .

Ultrasonics are used for industrial cleaning, but also in many medical and dental techniques: at the end of this process, fittings are bright, completely cleaned, sterilized and ready to be used even for very particular applications.

HYDRAULIC ASSEMBLING PROCEDURE*Insert Bore Collapse Control***PROCEDURA ASSEMBLAGGIO TUBI FLESSIBILI***Metodo di controllo del collasso foro***WIRE SPIRAL HOSES**

NOMINAL SIZE (inch)	INSERT COLLAPSE (mm)		GO, NO-GO MANDRELS (GAUGES) DIAMETERS (mm)			
			MULTISPIRAL TYPE		INTERLOCK TYPE	
	MINIMUM	MAXIMUM	NO-GO	GO	NO-GO	GO
1/4"	0.40	0.80				
3/8"	0.70	1.40				
1/2"	0.85	1.70				
5/8"	1.00	2.00			10.90	10.05
3/4"	1.10	2.20			13.80	12.90
1"	1.30	2.60			18.55	17.50
1" 1/4	1.45	2.90			21.35	20.25
1" 1/2	1.50	3.00			27.90	26.85
2"	1.75	3.50			37.00	35.70

WIRE BRAID HOSES

NOMINAL SIZE (inch)	INSERT COLLAPSE (mm)		GO, NO-GO MANDRELS (GAUGES) DIAMETERS (mm)	
			for STANDARD TYPE	
	MINIMUM	MAXIMUM	NO-GO	GO
3/16"	0.25	0.55	2.80	2.30
1/4"	0.30	0.65	3.75	3.20
5/16"	0.35	0.75	5.20	4.65
3/8"	0.40	1.00	6.60	5.90
1/2"	0.50	1.20	9.05	8.25
5/8"	0.60	1.35	11.40	10.60
3/4"	0.65	1.45	14.30	13.40
1"	0.70	1.55	19.50	18.40
1" 1/4	1.00	2.00	23.90	23.15
1" 1/2	1.15	2.30	29.70	28.80
2"	1.25	2.50	38.60	37.70
2" 3/8	1.00	2.00	49.50	48.50
2" 1/2	1.00	2.00	53.80	52.80
3"	0.80	1.80	65.00	64.00

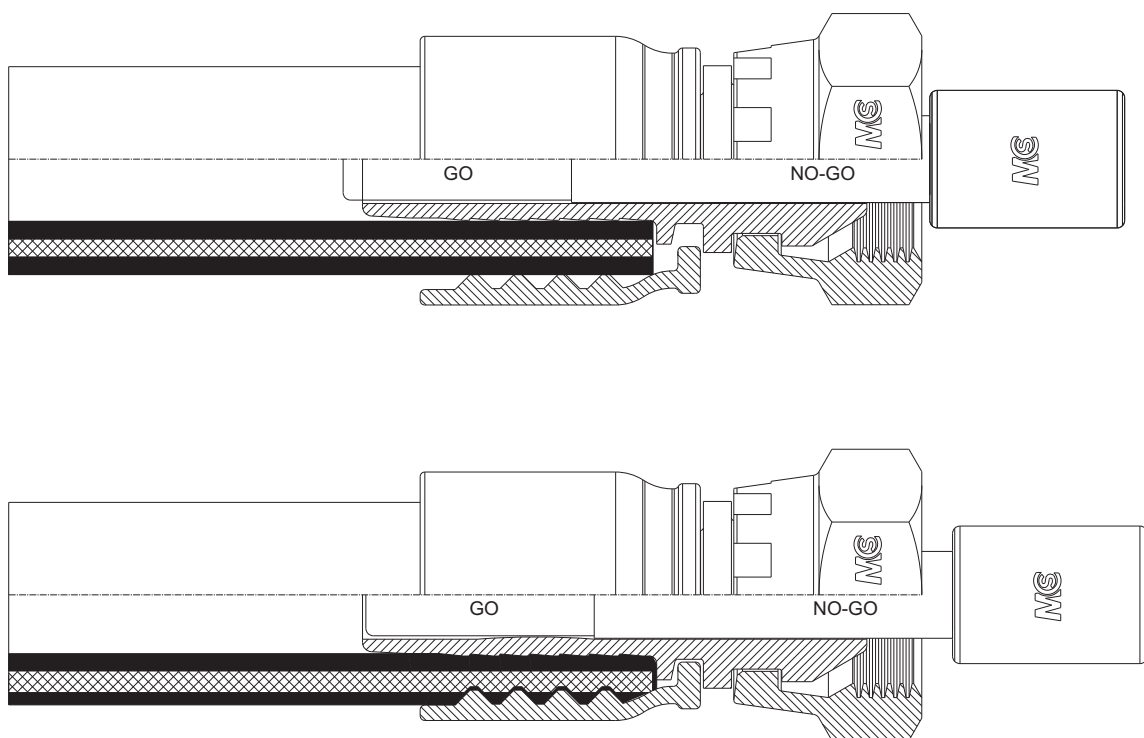

We suggest to control the collapse of the insert diameter using the go not go gauges

Suggeriamo di controllare il collasso del diametro dell'inserto utilizzando i tamponi passa non passa



FEMMINA GIREVOLE GAS CONO 60°
BSP SWIVEL FEMALE 60° CONE
- DKR -

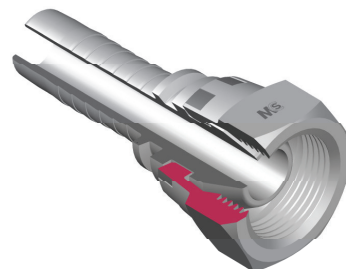
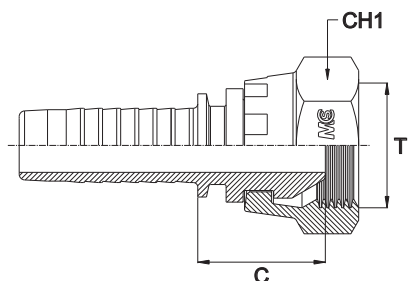

Bar W.P.	Codice Part Number	Filetto Thread	Ø Int. Tubo Inch. Hose I.D.	C Cut - Off	CH1
415	BSPSF0202	1/8"	1/8"	17	17
	BSPSF0203	1/8"	3/16"	17	17
	BSPSF0204	1/8"	1/4"	17	17
	BSPSF0402	1/4"	1/8"	17	19
	BSPSF0403	1/4"	3/16"	17	19
450	BSPSF0404	1/4"	1/4"	17	19
350	BSPSF0405	1/4"	5/16"	17	19
450	BSPSF0406	1/4"	3/8"	17	19
415	BSPSF0603	3/8"	3/16"	19	22
450	BSPSF0604	3/8"	1/4"	19	22
350	BSPSF0605	3/8"	5/16"	20	22
450	BSPSF0606	3/8"	3/8"	19	22
415	BSPSF0608	3/8"	1/2"	19	22
450	BSPSF0804	1/2"	1/4"	22	27
350	BSPSF0805	1/2"	5/16"	23	27
450	BSPSF0806	1/2"	3/8"	22	27
415	BSPSF0808	1/2"	1/2"	23	27
350	BSPSF0810	1/2"	5/8"	25	27
	BSPSF0812	1/2"	3/4"	24	27
415	BSPSF1008	5/8"	1/2"	25	30
350	BSPSF1010	5/8"	5/8"	25	30
250	BSPSF1012	5/8"	3/4"	24	30
415	BSPSF1206	3/4"	3/8"	24	32
	BSPSF1208	3/4"	1/2"	24	32
350	BSPSF1210	3/4"	5/8"	27	32
	BSPSF1212	3/4"	3/4"	25	32
280	BSPSF1216	3/4"	1"	27	32
350	BSPSF1612	1"	3/4"	26	38
280	BSPSF1616	1"	1"	27	38
210	BSPSF1620	1"	1"1/4"	28	38
280	BSPSF2016	1"1/4"	1"	27	50
210	BSPSF2020	1"1/4"	1"1/4"	28	50
	BSPSF2420	1"1/2"	1"1/4"	32	55
185	BSPSF2424	1"1/2"	1"1/2"	33	55
	BSPSF3224	2"	1"1/2"	31	70
165	BSPSF3232	2"	2"	31	70
120	BSPSF4040	2"1/2"	2"1/2"	36	85
70	BSPSF4848	3"	3"	38	100

FEMMINA GIREVOLE A 45° GAS CONO 60°
45° BSP SWIVEL FEMALE 60° CONE
- DKR 45° -

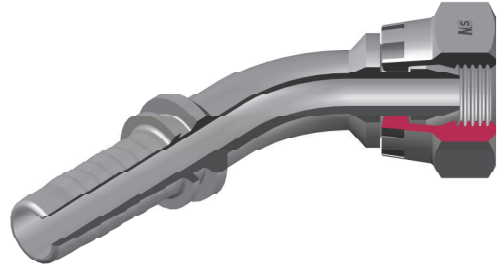
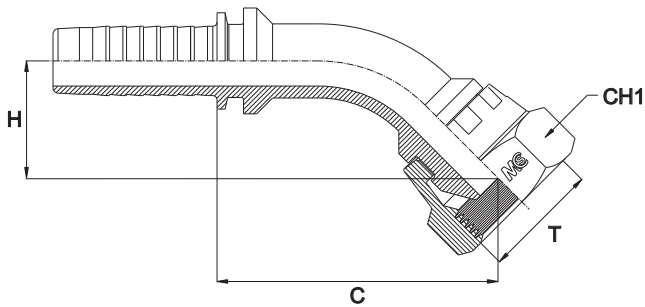

Bar W.P.	Codice Part Number	Filetto Thread	Ø Int. Tubo Inch. Hose I.D.	C Cut - Off	H Drop	CH1
415	45BSPSF0202	1/8"	1/8"	39,0	17,0	17
	45BSPSF0402	1/4"	1/8"	39,0	17,0	19
	45BSPSF0203	1/8"	3/16"	39,0	15,5	17
	45BSPSF0204	1/8"	1/4"	39,5	16,5	17
	45BSPSF0403	1/4"	3/16"	39,0	15,5	19
450	45BSPSF0404	1/4"	1/4"	39,5	16,5	19
350	45BSPSF0405	1/4"	5/16"	37,0	16,0	19
450	45BSPSF0406	1/4"	3/8"	54,0	15,5	19
	45BSPSF0604	3/8"	1/4"	38,5	22,5	22
350	45BSPSF0605	3/8"	5/16"	58,0	30,0	22
450	45BSPSF0606	3/8"	3/8"	56,0	22,0	22
415	45BSPSF0608	3/8"	1/2"	-	-	22
350	45BSPSF0805	1/2"	5/16"	-	-	27
450	45BSPSF0806	1/2"	3/8"	57,5	22,0	27
415	45BSPSF0808	1/2"	1/2"	63,5	24,0	27
350	45BSPSF0810	1/2"	5/8"	76,0	26,5	27
	45BSPSF0812	1/2"	3/4"	87,4	27,5	27
415	45BSPSF1008	5/8"	1/2"	-	-	30
350	45BSPSF1010	5/8"	5/8"	72,0	21,0	30
415	45BSPSF1208	3/4"	1/2"	-	-	32
350	45BSPSF1210	3/4"	5/8"	76,5	27,5	32
	45BSPSF1212	3/4"	3/4"	86,5	32,5	32
	45BSPSF1612	1"	3/4"	89,0	34,0	38
280	45BSPSF1616	1"	1"	112,5	38,5	38
	45BSPSF2016	1"1/4"	1"	-	-	50
150	45BSPSF2020	1"1/4"	1"1/4"	145,5	45,0	50
210	45BSPSF2420	1"1/2"	1"1/4"	-	-	55
185	45BSPSF2424	1"1/2"	1"1/2"	172,5	55,5	55
	45BSPSF3224*	2"	1"1/2"	-	-	70
165	45BSPSF3232	2"	2"	187,0	50,0	70
	45BSPSF4040*	2"1/2"	2"1/2"	85,5	45,0	85

* Saldato

* Welded

FEMMINA GIREVOLE A 90° GAS CONO 60°
90° BSP SWIVEL FEMALE 60° CONE
- DKR 90° -

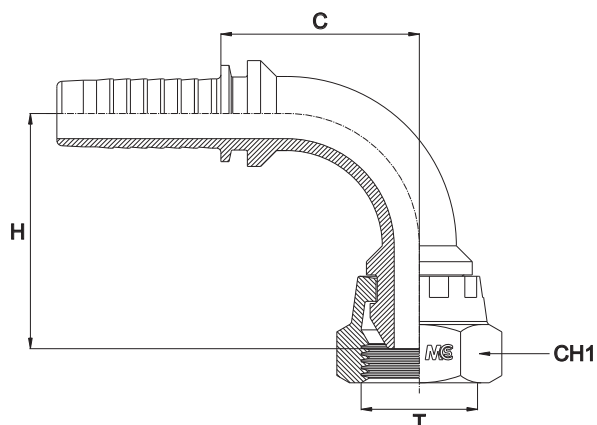

Bar W.P.	Codice Part Number	Filetto Thread	Ø Int. Tubo Inch. Hose I.D.	C Cut - Off	H Drop	CH1
415	90BSPSF0202	1/8"	1/8"	23,5	26,5	17
	90BSPSF0402	1/4"	1/8"	23,5	26,5	19
	90BSPSF0203	1/8"	3/16"	28,5	29,0	17
	90BSPSF0204	1/8"	1/4"	23,5	26,5	17
	90BSPSF0403	1/4"	3/16"	28,5	28,0	19
450	90BSPSF0404	1/4"	1/4"	23,5	27,5	19
350	90BSPSF0405	1/4"	5/16"	25,5	25,5	19
450	90BSPSF0406	1/4"	3/8"	34,5	34,5	19
	90BSPSF0604	3/8"	1/4"	23,5	35,5	22
350	90BSPSF0605	3/8"	5/16"	25,5	36,0	22
450	90BSPSF0606	3/8"	3/8"	34,5	36,5	22
415	90BSPSF0608	3/8"	1/2"	37,5	44,5	22
350	90BSPSF0805	1/2"	5/16"	25,5	-	27
450	90BSPSF0806	1/2"	3/8"	34,5	37,0	27
415	90BSPSF0808	1/2"	1/2"	37,5	44,5	27
350	90BSPSF0810	1/2"	5/8"	44,5	52,0	27
	90BSPSF0812	1/2"	3/4"	52,5	59,5	27
415	90BSPSF1008	5/8"	1/2"	37,5	-	30
350	90BSPSF1010	5/8"	5/8"	44,5	52,5	30
415	90BSPSF1208	3/4"	1/2"	37,5	47,0	32
350	90BSPSF1210	3/4"	5/8"	44,5	52,0	32
	90BSPSF1212	3/4"	3/4"	52,5	59,0	32
	90BSPSF1612	1"	3/4"	52,5	62,0	38
280	90BSPSF1616	1"	1"	67,5	74,5	38
	90BSPSF2016	1"1/4"	1"	67,5	-	50
150	90BSPSF2020	1"1/4"	1"1/4"	89,0	85,7	50
210	90BSPSF2420	1"1/2"	1"1/4"	85,0	103,0	55
185	90BSPSF2424	1"1/2"	1"1/2"	114,0	110,0	55
	90BSPSF3224*	2"	1"1/2"	114,0	-	70
165	90BSPSF3232	2"	2"	126,0	122,0	70
70	90BSPSF4040*	2"1/2"	2"1/2"	102,0	122,0	85
50	90BSPSF4848*	3"	3"	-	-	100

* Saldatura

* Welded

FEMMINA GIREVOLE O'RING FILETTO METRICO CONO 24° - SERIE LEGGERA

O'RING METRIC SWIVEL FEMALE 24° CONE - LIGHT TYPE

- DKOL -

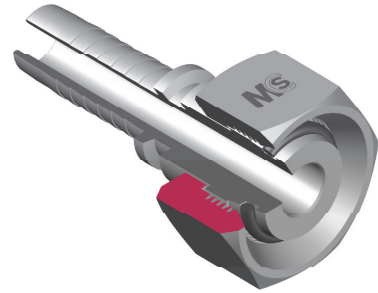
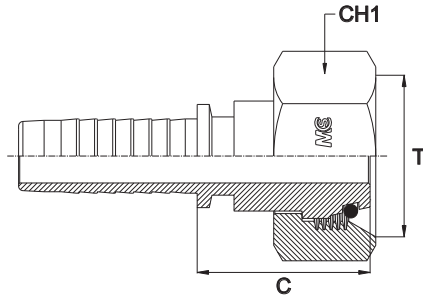

Bar W.P.	Codice Part Number	Filetto Thread	Ø Int. Tubo Inch. Hose I.D.	DIN 24°	C Cut - Off	CH1
280	ORMSFL0602	12x1,5	1/8"	06L	22,5	14
	ORMSFL0603	12x1,5	3/16"	06L	22,5	14
	ORMSFL0604	12x1,5	1/4"	06L	21,5	14
	ORMSFL0803	14x1,5	3/16"	08L	22,5	17
	ORMSFL0804	14x1,5	1/4"	08L	21,5	17
	ORMSFL0805	14x1,5	5/16"	08L	23,0	17
	ORMSFL0806*	14x1,5	3/8"	08L	21,0	17
	ORMSFL1003	16x1,5	3/16"	10L	26,0	19
	ORMSFL1004	16x1,5	1/4"	10L	26,0	19
	ORMSFL1005	16x1,5	5/16"	10L	26,0	19
	ORMSFL1006	16x1,5	3/8"	10L	26,0	19
	ORMSFL1204	18x1,5	1/4"	12L	24,5	22
	ORMSFL1205	18x1,5	5/16"	12L	26,0	22
	ORMSFL1206	18x1,5	3/8"	12L	26,0	22
	ORMSFL1208*	18x1,5	1/2"	12L	22,5	22
	ORMSFL1505	22x1,5	5/16"	15L	27,0	27
	ORMSFL1506	22x1,5	3/8"	15L	27,0	27
	ORMSFL1508	22x1,5	1/2"	15L	27,0	27
ORMSFL1510	22x1,5	5/8"	15L	27,0	27	
ORMSFL1512*	22x1,5	3/4"	15L	27,6	27	
ORMSFL1806	26x1,5	3/8"	18L	30,5	32	
210	ORMSFL1808	26x1,5	1/2"	18L	30,5	32
	ORMSFL1810	26x1,5	5/8"	18L	30,5	32
	ORMSFL1812*	26x1,5	3/4"	18L	31,0	32
	ORMSFL2208	30x2	1/2"	22L	36,0	36
	ORMSFL2210	30x2	5/8"	22L	36,0	36
	ORMSFL2212	30x2	3/4"	22L	36,5	36
165	ORMSFL2216*	30x2	1"	22L	31,0	36
	ORMSFL2810	36x2	5/8"	28L	37,0	41
	ORMSFL2812	36x2	3/4"	28L	37,0	41
	ORMSFL2816	36x2	1"	28L	37,0	41
125	ORMSFL2820*	36x2	1"1/4	28L	36,5	41
	ORMSFL3520	45x2	1"1/4	35L	36,5	50
100	ORMSFL4224	52x2	1"1/2	42L	36,5	60

* Dado Pressato

* Crimping Nut

FEMMINA GIREVOLE O'RING FILETTO METRICO CONO 24° - SERIE PESANTE O'RING METRIC SWIVEL FEMALE 24° CONE - HEAVY TYPE - DKOS -

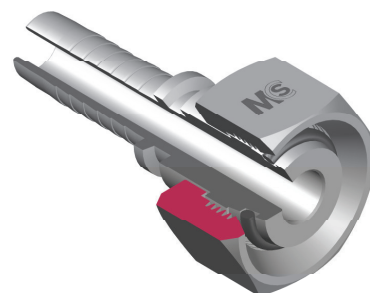
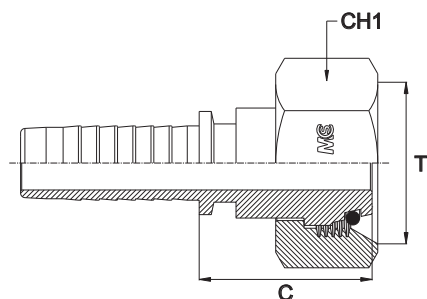

Bar W.P.	Codice Part Number	Filetto Thread	Ø Int. Tubo Inch. Hose I.D.	DIN 24°	C Cut - Off	CH1
420	ORMSFH0603	14x1,5	3/16"	06S	22,5	17
450	ORMSFH0604	14x1,5	1/4"	06S	22,5	17
420	ORMSFH0803	16x1,5	3/16"	08S	22,5	19
450	ORMSFH0804	16x1,5	1/4"	08S	22,5	19
350	ORMSFH0805	16x1,5	5/16"	08S	26,0	19
	ORMSFH0806	16x1,5	3/8"	08S	26,0	19
450	ORMSFH1004	18x1,5	1/4"	10S	26,0	22
350	ORMSFH1005	18x1,5	5/16"	10S	25,5	22
	ORMSFH1006	18x1,5	3/8"	10S	26,0	22
450	ORMSFH1204	20x1,5	1/4"	12S	26,0	24
350	ORMSFH1205	20x1,5	5/16"	12S	26,0	24
450	ORMSFH1206	20x1,5	3/8"	12S	26,0	24
420	ORMSFH1208	20x1,5	1/2"	12S	27,0	24
350	ORMSFH1405	22x1,5	5/16"	14S	27,0	27
450	ORMSFH1406	22x1,5	3/8"	14S	26,5	27
	ORMSFH1408	22x1,5	1/2"	14S	26,0	27
420	ORMSFH1606	24x1,5	3/8"	16S	32,0	30
	ORMSFH1608	24x1,5	1/2"	16S	32,0	30
	ORMSFH1610	24x1,5	5/8"	16S	36,0	30
	ORMSFH2008	30x2	1/2"	20S	36,0	36
350	ORMSFH2010	30x2	5/8"	20S	36,0	36
	ORMSFH2012	30x2	3/4"	20S	36,5	36
	ORMSFH2510	36x2	5/8"	25S	36,5	46
	ORMSFH2512	36x2	3/4"	25S	36,5	46
	ORMSFH2516	36x2	1"	25S	37,0	46
280	ORMSFH3012	42x2	3/4"	30S	36,5	50
	ORMSFH3016	42x2	1"	30S	37,0	50
	ORMSFH3020*	42x2	1" 1/4	30S	36,5	50
210	ORMSFH3816	52x2	1"	38S	37,0	60
	ORMSFH3820	52x2	1" 1/4	38S	42,5	60
185	ORMSFH3824	52x2	1" 1/2	38S	42,5	60
	ORMSFH5024	68x2	1" 1/2	50S	37,0	80

* Dado Pressato

* Crimping Nut

FEMMINA GIREVOLE 45° O'RING FILETTO METRICO CONO 24° - SERIE LEGGERA
45° O'RING METRIC SWIVEL FEMALE 24° CONE - LIGHT TYPE
- DKOL 45° -

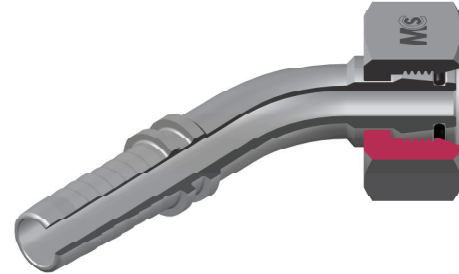
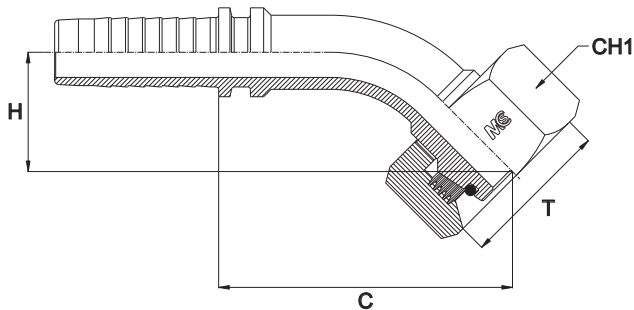

Bar W.P.	Codice Part Number	Filetto Thread	Ø Int. Tubo Inch. Hose I.D.	DIN 24°	C Cut - Off	H Drop	CH1
280	450RMSFLO603	12x1,5	3/16"	06L	44,0	22,0	14
	450RMSFLO604	12x1,5	1/4"	06L	43,5	15,7	14
	450RMSFLO803	14x1,5	3/16"	08L	43,5	19,5	17
	450RMSFLO804	14x1,5	1/4"	08L	50,0	18,0	17
	450RMSFLO805	14x1,5	5/16"	08L	-	-	17
	450RMSFL1004	16x1,5	1/4"	10L	48,0	19,0	19
	450RMSFL1005	16x1,5	5/16"	10L	59,0	19,5	19
	450RMSFL1006	16x1,5	3/8"	10L	55,0	18,0	19
	450RMSFL1204	18x1,5	1/4"	12L	46,0	32,0	22
	450RMSFL1205	18x1,5	5/16"	12L	59,0	22,0	22
	450RMSFL1206	18x1,5	3/8"	12L	56,5	21,0	22
	450RMSFL1208*	18x1,5	1/2"	12L	62,0	20,5	22
	450RMSFL1506	22x1,5	3/8"	15L	-	-	27
	450RMSFL1508	22x1,5	1/2"	15L	68,0	25,5	27
210	450RMSFL1806	26x1,5	3/8"	18L	-	-	32
	450RMSFL1808	26x1,5	1/2"	18L	70,5	28,5	32
	450RMSFL1810	26x1,5	5/8"	18L	75,5	28,0	32
	450RMSFL1812	26x1,5	3/4"	18L	85,0	22,5	32
	450RMSFL2210	30x2	5/8"	22L	-	-	36
	450RMSFL2212	30x2	3/4"	22L	88,5	33,0	36
165	450RMSFL2812	36x2	3/4"	28L	86,0	27,5	41
	450RMSFL2816	36x2	1"	28L	108,0	37,0	41
125	450RMSFL3520	45x2	1" 1/4	35L	132,5	32,5	50
100	450RMSFL4224	52x2	1" 1/2	42L	-	-	60

* Dado Pressato

* Crimping Nut

FEMMINA GIREVOLE 45° O'RING FILETTO METRICO CONO 24° - SERIE PESANTE
45° O'RING METRIC SWIVEL FEMALE 24° CONE - HEAVY TYPE
- DKOS 45° -

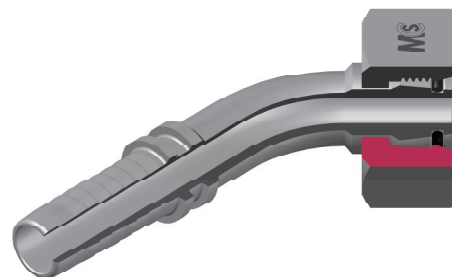
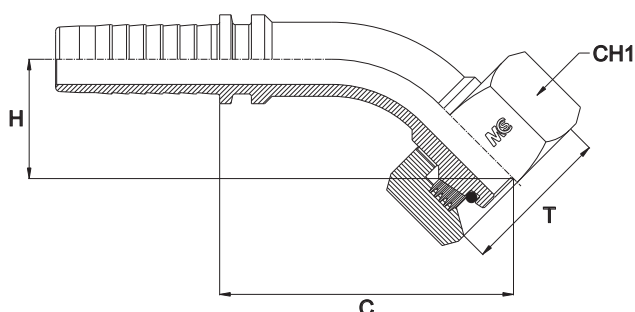

Bar W.P.	Codice Part Number	Filetto Thread	Ø Int. Tubo Inch. Hose I.D.	DIN 24°	C Cut - Off	H Drop	CH1
420	45ORMSFH0603	14x1,5	3/16"	06S	-	-	17
450	45ORMSFH0604	14x1,5	1/4"	06S	-	-	17
420	45ORMSFH0803	16x1,5	3/16"	08S	-	-	19
450	45ORMSFH0804	16x1,5	1/4"	08S	47,0	16,5	19
350	45ORMSFH0805	16x1,5	5/16"	08S	-	-	19
450	45ORMSFH1004	18x1,5	1/4"	10S	48,5	22,5	22
350	45ORMSFH1005	18x1,5	5/16"	10S	-	-	22
450	45ORMSFH1006	18x1,5	3/8"	10S	55,0	19,0	22
	45ORMSFH1204	20x1,5	1/4"	12S	-	-	24
350	45ORMSFH1205	20x1,5	5/16"	12S	55,0	18,5	24
450	45ORMSFH1206	20x1,5	3/8"	12S	58,5	22,5	24
420	45ORMSFH1208	20x1,5	1/2"	12S	-	-	24
450	45ORMSFH1406	22x1,5	3/8"	14S	57,0	25,5	27
	45ORMSFH1408	22x1,5	1/2"	14S	-	-	27
420	45ORMSFH1606	24x1,5	3/8"	16S	-	-	30
	45ORMSFH1608	24x1,5	1/2"	16S	67,5	28,0	30
350	45ORMSFH1610	24x1,5	5/8"	16S	68,0	23,0	30
	45ORMSFH2008	30x2	1/2"	20S	-	-	36
	45ORMSFH2010	30x2	5/8"	20S	73,5	28,5	36
	45ORMSFH2012	30x2	3/4"	20S	87,0	29,5	36
	45ORMSFH2512	36x2	3/4"	25S	89,5	35,0	46
280	45ORMSFH2516	36x2	1"	25S	110,5	35,0	46
	45ORMSFH3012	42x2	3/4"	30S	89,0	30,5	50
	45ORMSFH3016	42x2	1"	30S	110,5	35,0	50
210	45ORMSFH3820	52x2	1" 1/4	38S	138,0	62,0	60
185	45ORMSFH3824	52x2	1" 1/2	38S	-	-	60
	45ORMSFH5024	68x2	1" 1/2	50S	-	-	80

FEMMINA GIREVOLE 90° O'RING FILETTO METRICO CONO 24° - SERIE LEGGERA
90° O'RING METRIC SWIVEL FEMALE 24° CONE - LIGHT TYPE
- DKOL 90° -

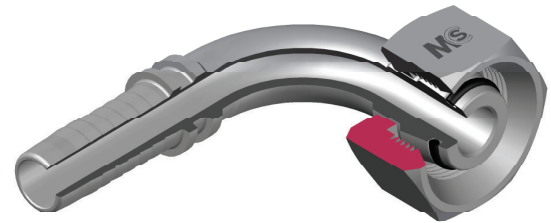
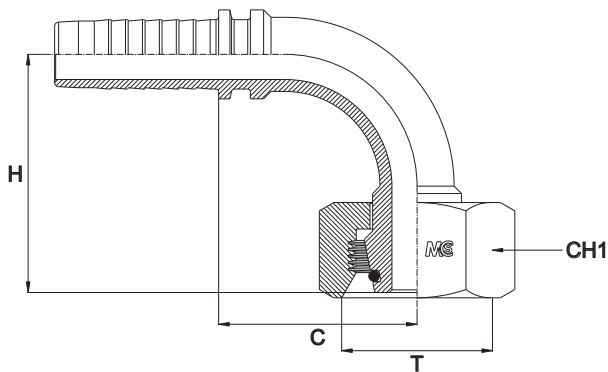

Bar W.P.	Codice Part Number	Filetto Thread	Ø Int. Tubo Inch. Hose I.D.	DIN 24°	C Cut - Off	H Drop	CH1
280	900RMSFL0603	12x1,5	3/16"	06L	24,5	32,0	14
	900RMSFL0604	12x1,5	1/4"	06L	24,0	32,0	14
	900RMSFL0803	14x1,5	3/16"	08L	26,5	31,0	17
	900RMSFL0804	14x1,5	1/4"	08L	24,0	32,0	17
	900RMSFL0805	14x1,5	5/16"	08L	33,5	39,1	17
	900RMSFL1003	16x1,5	3/16"	10L	27,5	35,0	17
	900RMSFL1004	16x1,5	1/4"	10L	28,0	34,5	19
	900RMSFL1005	16x1,5	5/16"	10L	37,0	36,5	19
	900RMSFL1006	16x1,5	3/8"	10L	35,0	37,5	19
	900RMSFL1204	18x1,5	1/4"	12L	27,0	36,5	22
	900RMSFL1205	18x1,5	5/16"	12L	37,0	36,5	22
	900RMSFL1206	18x1,5	3/8"	12L	35,5	36,5	22
	900RMSFL1208*	18x1,5	1/2"	12L	36,5	36,5	22
210	900RMSFL1506	22x1,5	3/8"	15L	40,0	38,5	27
	900RMSFL1508	22x1,5	1/2"	15L	37,5	45,0	27
	900RMSFL1806	26x1,5	1/2"	18L	39,0	38,5	32
	900RMSFL1808	26x1,5	1/2"	18L	39,0	49,0	32
	900RMSFL1810	26x1,5	5/8"	18L	44,0	48,5	32
	900RMSFL1812	26x1,5	3/4"	18L	52,0	63,0	32
165	900RMSFL2210	30x2	5/8"	22L	46,0	47,5	36
	900RMSFL2212	30x2	3/4"	22L	55,5	60,5	36
125	900RMSFL2812	36x2	3/4"	28L	56,0	61,0	41
	900RMSFL2816	36x2	1"	28L	62,5	79,5	41
100	900RMSFL3520	45x2	1" 1/4	35L	85,0	102,5	50
100	900RMSFL4224	52x2	1" 1/2	42L	107,0	111,0	60

* Dado Pressato

* Crimping Nut

FEMMINA GIREVOLE 90° O'RING FILETTO METRICO CONO 24° - SERIE PESANTE
90° O'RING METRIC SWIVEL FEMALE 24° CONE - HEAVY TYPE
- DKOS 90° -

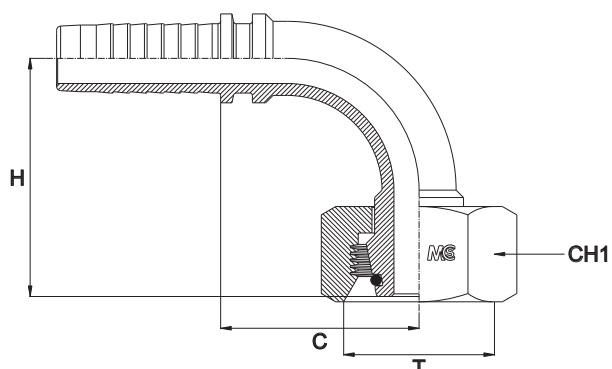

Bar W.P.	Codice Part Number	Filetto Thread	Ø Int. Tubo Inch. Hose I.D.	DIN 24°	C Cut - Off	H Drop	CH1
420	900RMSFH0603	14x1,5	3/16"	06S	24,5	32,0	17
450	900RMSFH0604	14x1,5	1/4"	06S	27,0	32,0	17
420	900RMSFH0803	16x1,5	3/16"	08S	27,0	32,0	19
450	900RMSFH0804	16x1,5	1/4"	08S	22,5	33,5	19
350	900RMSFH0805	16x1,5	5/16"	08S	37,0	36,5	19
350	900RMSFH0806	16x1,5	3/8"	08S	35,0	37,5	19
450	900RMSFH1004	18x1,5	1/4"	10S	28,0	35,5	22
350	900RMSFH1005	18x1,5	5/16"	10S	37,0	36,5	22
450	900RMSFH1006	18x1,5	3/8"	10S	37,0	37,5	22
	900RMSFH1204	20x1,5	1/4"	12S	27,0	36,5	24
350	900RMSFH1205	20x1,5	5/16"	12S	37,0	37,0	24
450	900RMSFH1206	20x1,5	3/8"	12S	35,5	36,5	24
420	900RMSFH1208	20x1,5	1/2"	12S	37,0	47,5	24
450	900RMSFH1406	22x1,5	3/8"	14S	39,5	38,5	27
420	900RMSFH1408	22x1,5	1/2"	14S	40,0	46,5	27
	900RMSFH1606	24x1,5	3/8"	16S	35,4	43,0	30
	900RMSFH1608	24x1,5	1/2"	16S	36,5	45,5	30
350	900RMSFH1610	24x1,5	5/8"	16S	42,0	50,0	30
	900RMSFH2008	30x2	1/2"	20S	40,0	48,0	36
	900RMSFH2010	30x2	5/8"	20S	42,0	50,0	36
	900RMSFH2012	30x2	3/4"	20S	47,5	65,5	36
	900RMSFH2512	36x2	3/4"	25S	55,5	60,5	46
280	900RMSFH2516	36x2	1"	25S	69,5	74,5	46
	900RMSFH3012	42x2	3/4"	30S	53,0	65,0	50
210	900RMSFH3016	42x2	1"	30S	68,0	78,5	50
	900RMSFH3820	52x2	1" 1/4	38S	84,0	93,0	60
185	900RMSFH3824	52x2	1" 1/2	38S	108,0	112,0	60
	900RMSFH5024	68x2	1" 1/2	50S	-	-	80

FEMMINA METRICA OGIVA 24/60°
METRIC FEMALE 24/60° CONE LIGHT MULTISEAL
- DKL -

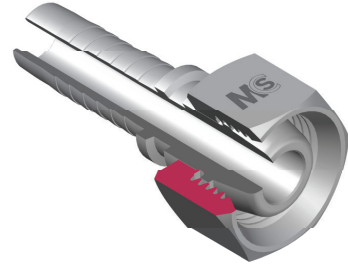
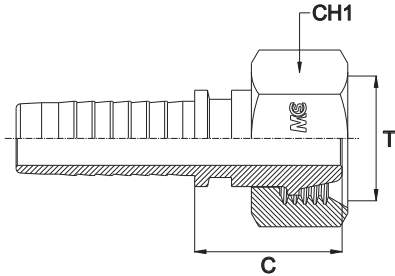

Bar W.P.	Codice Part Number	Filetto Thread	Ø Int. Tubo Inch. Hose I.D.	C Cut - Off	CH1
280	MSFLMS1203	12x1,5	3/16"	22,0	14
	MSFLMS1204	12x1,5	1/4"	22,5	14
	MSFLMS1403	14x1,5	3/16"	22,5	17
	MSFLMS1404	14x1,5	1/4"	22,5	17
	MSFLMS1405*	14x1,5	5/16"	21,0	17
	MSFLMS1604	16x1,5	1/4"	26,0	19
	MSFLMS1605	16x1,5	5/16"	26,0	19
	MSFLMS1606	16x1,5	3/8"	26,0	19
	MSFLMS1804	18x1,5	1/4"	26,0	22
	MSFLMS1805	18x1,5	5/16"	26,0	22
	MSFLMS1806	18x1,5	3/8"	26,0	22
	MSFLMS2206	22x1,5	3/8"	27,0	27
MSFLMS2208	22x1,5	1/2"	26,0	27	
210	MSFLMS2608	26x1,5	1/2"	31,0	32
	MSFLMS2610	26x1,5	5/8"	30,5	32
	MSFLMS3012	30x2	3/4"	36,5	36
165	MSFLMS3616	36x2	1"	37,0	41
125	MSFLMS4520	45x2	1" 1/4	36,5	50
100	MSFLMS5224	52x2	1" 1/2	36,5	60

* Dado Pressato

* Crimping Nut

FEMMINA 90° METRICA OGIVA 24/60°
90° METRIC FEMALE 24/60° CONE LIGHT MULTISEAL
- DKL 90° -

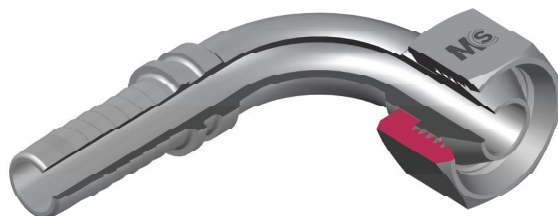
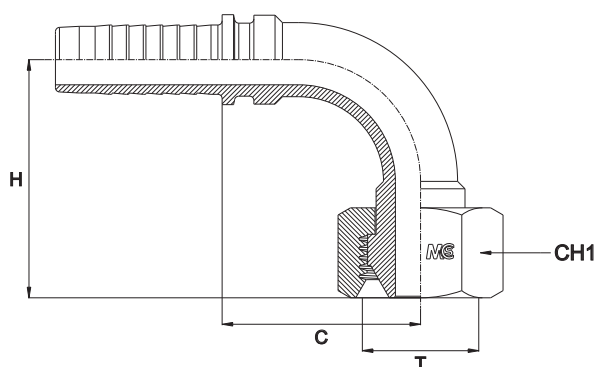

Bar W.P.	Codice Part Number	Filetto Thread	Ø Int. Tubo Inch. Hose I.D.	C Cut - Off	H Drop	CH1
280	90MSFLMS1203	12x1,5	3/16"	24,0	32,0	14
	90MSFLMS1204	12x1,5	1/4"	24,0	32,0	14
	90MSFLMS1404	14x1,5	1/4"	24,0	32,0	17
	90MSFLMS1405	14x1,5	5/16"	24,0	32,0	17
	90MSFLMS1604	16x1,5	1/4"	28,0	34,5	19
	90MSFLMS1605	16x1,5	5/16"	37,0	36,5	19
	90MSFLMS1606	16x1,5	3/8"	35,0	37,5	19
	90MSFLMS1804	18x1,5	1/4"	27,0	36,5	22
	90MSFLMS1805	18x1,5	5/16"	37,0	36,5	22
	90MSFLMS1806	18x1,5	3/8"	35,5	36,5	22
210	90MSFLMS2206	22x1,5	3/8"	40,0	38,5	27
	90MSFLMS2208	22x1,5	1/2"	37,5	45,0	27
	90MSFLMS2608	26x1,5	1/2"	39,0	49,0	32
165	90MSFLMS2610	26x1,5	5/8"	44,0	48,5	32
	90MSFLMS3012	30x2	3/4"	55,5	60,5	36
125	90MSFLMS3616	36x2	1"	70,5	75,0	41
100	90MSFLMS4520	45x2	1" 1/4	85,0	93,5	50
	90MSFLMS5224	52x2	1" 1/2	107,0	111,0	60

* Disponibile anche a 45°

* Also Available 45°

FEMMINA METRICA CONO 60°
METRIC FEMALE 60° CONE
- DKM -

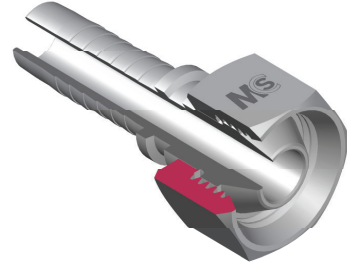
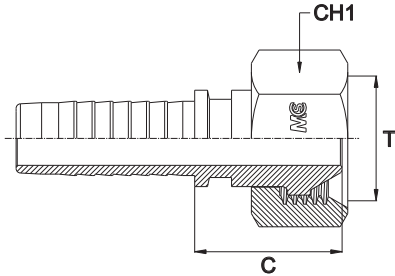

Bar W.P.	Codice Part Number	Filetto Thread	Ø Int. Tubo Inch. Hose I.D.	C Cut - Off	CH1
350	MSFL1203	12x1,5	3/16"	22,0	14
	MSFL1204	12x1,5	1/4"	21,5	14
	MSFL1404	14x1,5	1/4"	21,5	17
	MSFL1405*	14x1,5	5/16"	21,0	17
	MSFL1604	16x1,5	1/4"	21,5	19
	MSFL1605	16x1,5	5/16"	26,0	19
315	MSFL1606	16x1,5	3/8"	26,0	19
	MSFL1608	16x1,5	1/2"	26,0	19
350	MSFL1804	18x1,5	1/4"	26,0	22
	MSFL1805	18x1,5	5/16"	26,0	22
	MSFL1806	18x1,5	3/8"	26,0	22
315	MSFL2006	20x1,5	3/8"	26,0	24
	MSFL2008	20x1,5	1/2"	27,0	24
	MSFL2206	22x1,5	3/8"	24,2	27
	MSFL2208	22x1,5	1/2"	26,0	27
250	MSFL2608	26x1,5	1/2"	31,0	32
	MSFL2610	26x1,5	5/8"	30,5	32
210	MSFL3012	30x1,5	3/4"	36,5	36
165	MSFL3816	38x1,5	1"	37,0	46
125	MSFL4520	45x1,5	1"1/4"	36,5	50

* Dado Pressato

* Crimping Nut

FEMMINA METRICA A 90° CONO 60°
90° METRIC FEMALE 60° CONE
- DKM 90° -

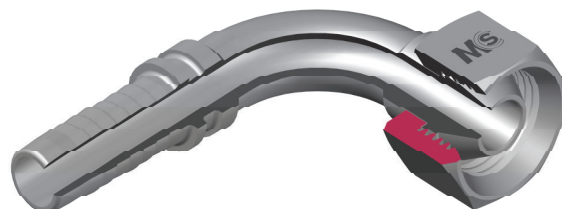
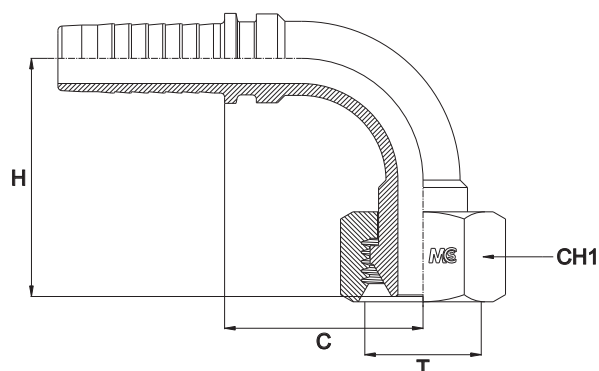

Bar W.P.	Codice Part Number	Filetto Thread	Ø Int. Tubo Inch. Hose I.D.	C Cut - Off	H Drop	CH1
350	90MSFL1203	12x1,5	3/16"	24,0	32,0	14
	90MSFL1204	12x1,5	1/4"	24,0	32,0	14
	90MSFL1404	14x1,5	1/4"	24,0	32,0	17
	90MSFL1604	16x1,5	1/4"	28,0	34,5	19
	90MSFL1605	16x1,5	5/16"	37,0	36,5	19
	90MSFL1606	16x1,5	3/8"	35,0	37,5	19
	90MSFL1805	18x1,5	5/16"	37,0	36,5	22
315	90MSFL1806	18x1,5	3/8"	35,5	36,5	22
	90MSFL2006	20x1,5	3/8"	35,5	36,5	24
250	90MSFL2208	22x1,5	1/2"	37,5	45,0	27
	90MSFL2608	26x1,5	1/2"	39,0	49,0	32
210	90MSFL2610	26x1,5	5/8"	44,0	48,5	32
165	90MSFL3012	30x1,5	3/4"	55,5	59,5	36
	90MSFL3816	38x1,5	1"	70,5	75,0	46

* Disponibile anche a 45°

* Also Available 45°

FEMMINA GIREVOLE JIC SVASATA 74°
JIC SWIVEL FEMALE 74° CONE
- DKJ -

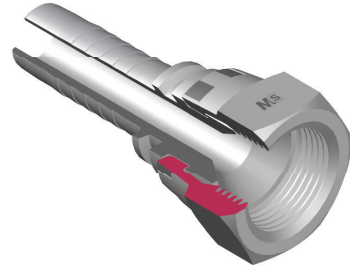
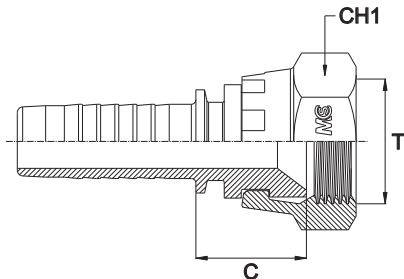

Bar W.P.	Codice Part Number	Filetto Thread	Ø Int. Tubo Inch. Hose I.D.	C Cut - Off	CH1
350	JSF0603	3/8"	3/16"	15,5	17
	JSF0703	7/16"	3/16"	15,5	17
	JSF0704	7/16"	1/4"	15,5	17
	JSF0705	7/16"	5/16"	15,5	17
	JSF0706	7/16"	3/8"	15,5	17
	JSF0803	1/2"	3/16"	15,5	17
	JSF0804	1/2"	1/4"	15,5	17
	JSF0805	1/2"	5/16"	15,5	17
250	JSF0806	1/2"	3/8"	15,5	17
	JSF0904	9/16"	1/4"	15,5	19
	JSF0905	9/16"	5/16"	15,5	19
	JSF0906	9/16"	3/8"	15,5	19
	JSF0908	9/16"	1/2"	16,5	19
	JSF1006	5/8"	3/8"	15,5	22
	JSF1204	3/4"	1/4"	19,0	24
	JSF1205	3/4"	5/16"	19,0	24
200	JSF1206	3/4"	3/8"	19,0	24
	JSF1208	3/4"	1/2"	19,5	24
	JSF1210	3/4"	5/8"	20,0	24
	JSF1212	3/4"	3/4"	20,5	24
	JSF1406	7/8"	3/8"	19,0	27
	JSF1408	7/8"	1/2"	19,5	27
	JSF1410	7/8"	5/8"	20,0	27
	JSF1412	7/8"	3/4"	20,5	27
160	JSF1708	1" 1/16	1/2"	23,0	32
	JSF1710	1" 1/16	5/8"	23,0	32
	JSF1712	1" 1/16	3/4"	23,0	32
	JSF1716	1" 1/16	1"	23,5	32
100	JSF2112	1" 5/16	3/4"	23,5	38
	JSF2116	1" 5/16	1"	24,5	38
125	JSF2120	1" 5/16	1" 1/4	25,5	38
	JSF2616	1" 5/8	1"	27,0	50
100	JSF2620	1" 5/8	1" 1/4	28,0	50
	JSF3020	1" 7/8	1" 1/4	28,0	55
80	JSF3024	1" 7/8	1" 1/2	28,0	55
	JSF4032	2" 1/2	2"	31,0	70

FEMMINA GIREVOLE 45° JIC SVASATA 74°
45° JIC SWIVEL FEMALE 74° CONE
- DKJ 45° -

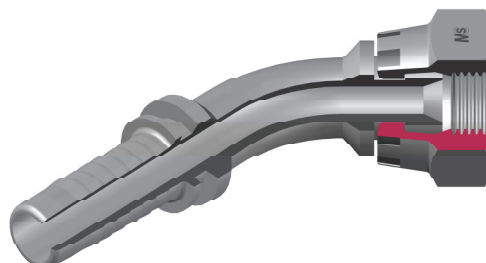
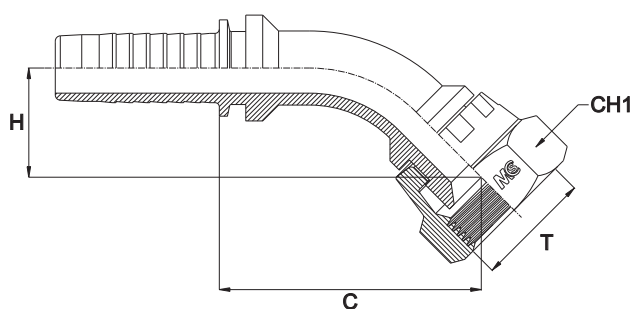

Bar W.P.	Codice Part Number	Filetto Thread	Ø Int. Tubo Inch. Hose I.D.	C Cut - Off	H Drop	CH1
350	45JSF0603	3/8"	3/16"	42,5	14,5	17
	45JSF0703	7/16"	3/16"	39,0	14,5	17
	45JSF0704	7/16"	1/4"	41,5	18,5	17
	45JSF0705	7/16"	5/16"	-	-	17
	45JSF0803	1/2"	3/16"	-	-	17
	45JSF0804	1/2"	1/4"	42,5	19,5	17
250	45JSF0805	1/2"	5/16"	38,3	12,0	17
	45JSF0806	1/2"	3/8"	59,0	20,5	17
	45JSF0904	9/16"	3/8"	61,5	23,0	19
	45JSF0905	9/16"	5/16"	68,5	26,0	19
	45JSF0906	9/16"	3/8"	52,5	16,5	19
	45JSF1204	3/4"	1/4"	46,0	11,5	24
	45JSF1206	3/4"	3/8"	56,0	16,0	24
	45JSF1208	3/4"	1/2"	64,0	20,0	24
200	45JSF1210	3/4"	5/8"	-	-	24
	45JSF1212	3/4"	3/4"	-	-	24
	45JSF1406	7/8"	3/8"	58,0	23,5	27
	45JSF1408	7/8"	1/2"	70,5	36,0	27
	45JSF1410	7/8"	5/8"	70,0	41,0	27
	45JSF1708	1" 1/16	1/2"	-	-	32
	45JSF1710	1" 1/16	5/8"	79,0	26,5	32
160	45JSF1712	1" 1/16	3/4"	98,5	35,0	32
	45JSF1716	1" 1/16	1"	-	-	32
125	45JSF2112	1" 5/16	3/4"	86,0	26,0	38
	45JSF2116	1" 5/16	1"	109,0	37,0	38
100	45JSF2616	1" 5/8	1"	-	-	50
	45JSF2620	1" 5/8	1" 1/4	134,0	43,0	50
80	45JSF3020	1" 7/8	1" 1/4	135,0	46,3	55
	45JSF3024	1" 7/8	1" 1/2	172,5	53,5	55
	45JSF4032	2" 1/2	2"	-	-	70

FEMMINA GIREVOLE 90° JIC SVASATA 74°
90° JIC SWIVEL FEMALE 74° CONE
- DKJ 90° -

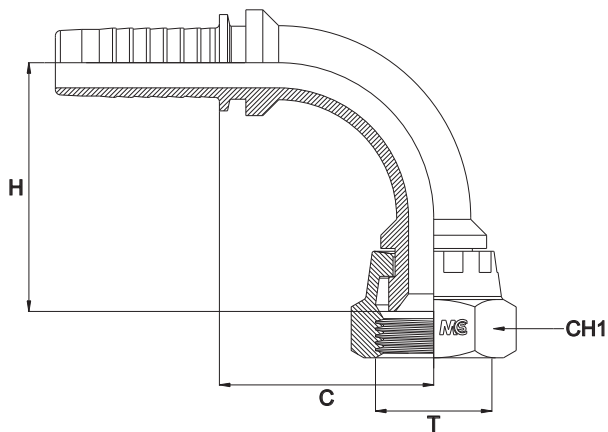

Bar W.P.	Codice Part Number	Filetto Thread	Ø Int. Tubo Inch. Hose I.D.	C Cut - Off	H Drop	CH1
350	90JSF0603	3/8"	3/16"	25,5	28,0	17
	90JSF0703	7/16"	3/16"	24,5	26,5	17
	90JSF0704	7/16"	1/4"	23,5	30,5	17
	90JSF0705	7/16"	5/16"	25,0	28,0	17
	90JSF0706	7/16"	3/8"	36,5	34,0	17
	90JSF0803	1/2"	3/16"	24,0	24,5	17
	90JSF0804	1/2"	1/4"	23,5	30,5	17
90JSF0805	1/2"	5/16"	24,5	27,0	17	
250	90JSF0806	1/2"	3/8"	36,5	33,0	17
	90JSF0904	9/16"	1/4"	22,0	35,0	19
	90JSF0905	9/16"	5/16"	38,5	37,5	19
	90JSF0906	9/16"	3/8"	35,0	36,0	19
	90JSF1204	3/4"	1/4"	24,0	34,0	24
	90JSF1205	3/4"	5/16"	-	-	24
	90JSF1206	3/4"	3/8"	40,0	46,5	24
	90JSF1208	3/4"	1/2"	36,5	45,0	24
200	90JSF1210	3/4"	5/8"	-	-	24
	90JSF1212	3/4"	3/4"	-	-	24
	90JSF1406	7/8"	3/8"	40,0	38,5	27
	90JSF1408	7/8"	1/2"	40,0	47,0	27
	90JSF1410	7/8"	5/8"	43,1	52,6	27
	90JSF1708	1" 1/16	1/2"	37,0	48,0	32
	90JSF1710	1" 1/16	5/8"	43,5	57,0	32
	90JSF1712	1" 1/16	3/4"	55,0	68,0	32
90JSF1716	1" 1/16	1"	-	-	32	
160	90JSF2112	1" 5/16	3/4"	53,5	70,5	38
	90JSF2116	1" 5/16	1"	70,5	88,0	38
125	90JSF2616	1" 5/8	1"	64,0	81,0	50
	90JSF2620	1" 5/8	1" 1/4	83,5	89,5	50
100	90JSF3020	1" 7/8	1" 1/4	88,0	89,0	55
	90JSF3024	1" 7/8	1" 1/2	113,5	110,5	55
80	90JSF4032	2" 1/2	2"	-	-	70

FEMMINA GIREVOLE JIC SVASATA 74° DOPPIO ESAGONO JIC SWIVEL FEMALE 74° CONE DOUBLE HEXAGON - DKJ -

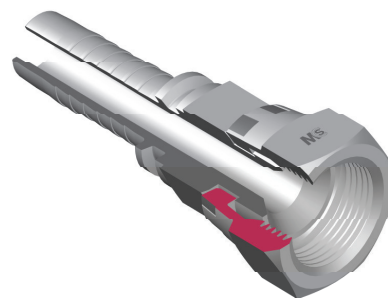
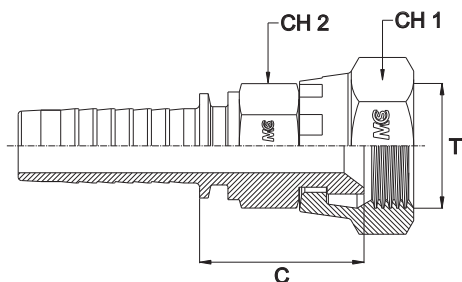

Bar W.P.	Codice Part Number	Filetto Thread	Ø Int. Tubo Inch. Hose I.D.	C Cut - Off	CH1	CH2
350	JSFDH0704	7/16"	1/4"	25,5	17	14
	JSFDH0804	1/2"	1/4"	25,5	17	14
250	JSFDH0805	1/2"	5/16"	-	17	14
	JSFDH0904	9/16"	1/4"	25,5	19	14
	JSFDH0905	9/16"	5/16"	25,5	19	14
	JSFDH0906	9/16"	3/8"	25,8	19	17
	JSFDH1206	3/4"	3/8"	28,8	24	19
	JSFDH1208	3/4"	1/2"	29,5	24	19
200	JSFDH1408	7/8"	1/2"	29,5	27	22
	JSFDH1410	7/8"	5/8"	31,0	27	22
	JSFDH1710	1" 1/16	5/8"	-	32	27
	JSFDH1712	1" 1/16	3/4"	34,0	32	27
160	JSFDH2116	1" 5/16	1"	35,5	38	32

FEMMINA GIREVOLE 60° JIS (TOYOTA) JIS SWIVEL FEMALE 60° CONE (TOYOTA) - JIS-T -

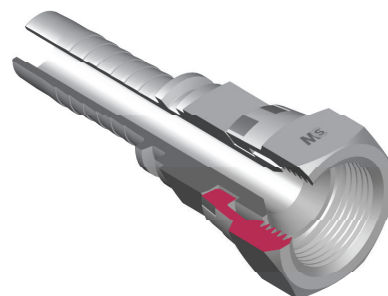
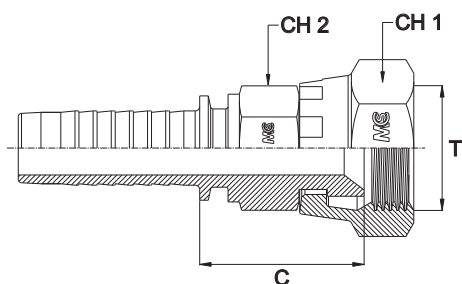

Bar W.P.	Codice Part Number	Filetto Thread	Ø Int. Tubo Inch. Hose I.D.	C Cut - Off	CH1	CH2
350	JIST0404	1/4"	1/4"	25,5	19	17
250	JIST0606	3/8"	3/8"	26,5	22	19
	JIST0808	1/2"	1/2"	28,5	27	22
200	JIST1212	3/4"	3/4"	34,0	32	30
160	JIST1616	1"	1"	35,5	38	36
100	JIST2020	1" 1/4	1" 1/4	-	50	46
	JIST2424	1" 1/2	1" 1/2	-	55	50

* Disponibile anche a 90°

* Also Available 90°

FEMMINA GIREVOLE GAS SEDE PIANA
BSP SWIVEL FEMALE FLAT SEAT
- DKR FLAT SEAT -

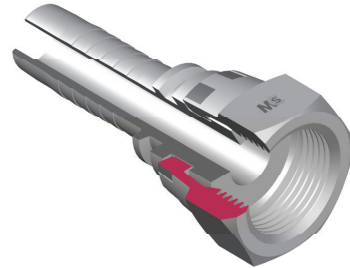
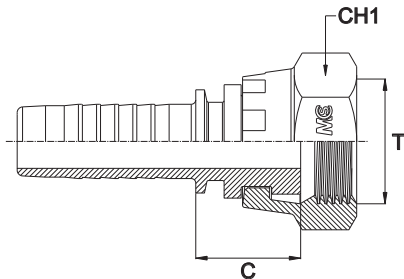

Bar W.P.	Codice Part Number	Filetto Thread	Ø Int. Tubo Inch. Hose I.D.	C Cut - Off	CH1
450	BSPSFFS0404	1/4"	1/4"	15,5	19
	BSPSFFS0405	1/4"	5/16"	16,0	19
	BSPSFFS0604	3/8"	1/4"	16,0	22
350	BSPSFFS0605	3/8"	5/16"	16,0	22
450	BSPSFFS0606	3/8"	3/8"	16,0	22
	BSPSFFS0806	1/2"	3/8"	18,0	27
415	BSPSFFS0808	1/2"	1/2"	18,5	27
350	BSPSFFS0810	1/2"	5/8"	20,5	27
415	BSPSFFS1008	5/8"	1/2"	18,5	30
350	BSPSFFS1010	5/8"	5/8"	20,0	30
415	BSPSFFS1208	3/4"	1/2"	21,0	32
350	BSPSFFS1210	3/4"	5/8"	24,0	32
	BSPSFFS1212	3/4"	3/4"	22,0	32
	BSPSFFS1612	1"	3/4"	23,0	38
280	BSPSFFS1616	1"	1"	24,0	38
210	BSPSFFS1620	1"	1" 1/4	25,0	38
	BSPSFFS2016	1" 1/4	1"	24,5	50
	BSPSFFS2020	1" 1/4	1" 1/4	25,5	50
185	BSPSFFS2424	1" 1/2	1" 1/2	27,0	55
165	BSPSFFS3232	2"	2"	28,0	70

FEMMINA GIREVOLE 90° GAS SEDE PIANA
90° BSP SWIVEL FEMALE FLAT SEAT
- DKR 90° FLAT SEAT -

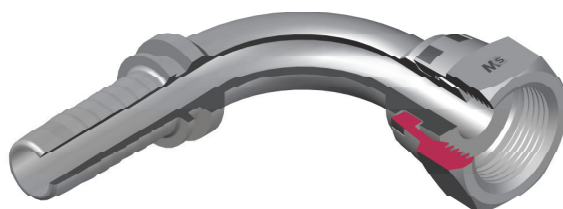
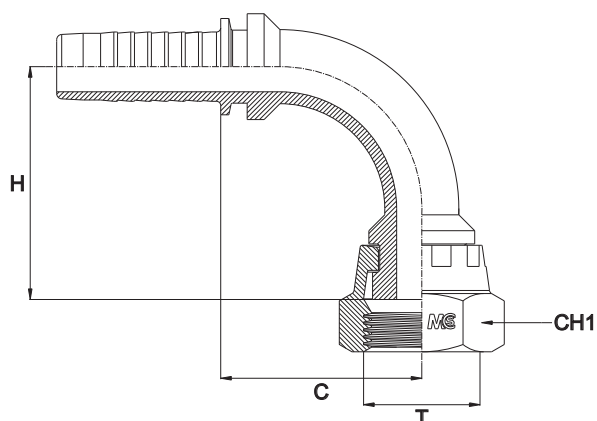

Bar W.P.	Codice Part Number	Filetto Thread	Ø Int. Tubo Inch. Hose I.D.	C Cut - Off	H Drop	CH1
450	90BSPSFFS0404	1/4"	1/4"	23,5	26,4	19
350	90BSPSFFS0405	1/4"	5/16"	25,5	24,4	19
450	90BSPSFFS0604	3/8"	1/4"	-	-	22
350	90BSPSFFS0605	3/8"	5/16"	25,5	33,0	22
450	90BSPSFFS0606	3/8"	3/8"	34,5	33,0	22
	90BSPSFFS0806	1/2"	3/8"	34,5	33,0	27
415	90BSPSFFS0808	1/2"	1/2"	37,5	40,5	27
350	90BSPSFFS0810	1/2"	5/8"	-	-	27
415	90BSPSFFS1008	5/8"	1/2"	-	-	30
350	90BSPSFFS1010	5/8"	5/8"	44,5	48,5	30
415	90BSPSFFS1206	3/4"	3/8"	35,5	44,0	32
	90BSPSFFS1208	3/4"	1/2"	37,5	44,0	32
350	90BSPSFFS1210	3/4"	5/8"	44,5	49,0	32
	90BSPSFFS1212	3/4"	3/4"	52,5	56,0	32
280	90BSPSFFS1616	1"	1"	52,5	71,5	38
210	90BSPSFFS2020	1" 1/4	1" 1/4	67,5	83,0	50
185	90BSPSFFS2424	1" 1/2	1" 1/2	-	-	55
165	90BSPSFFS3232	2"	2"	126,0	119,0	70

* Disponibile anche a 45°

* Also Available 45°

FEMMINA GIREVOLE NPSM CONO 60°
NPSM SWIVEL FEMALE 60° CONE
- DKN -

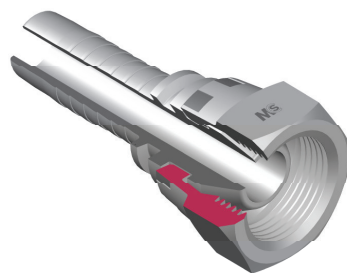
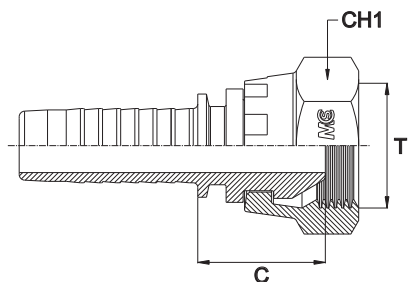

Codice Part Number	Filetto Thread	Ø Int. Tubo Inch. Hose I.D.	C Cut - Off	CH1
NPSMSF0404	1/4"	1/4"	17,0	19
NPSMSF0606	3/8"	3/8"	19,0	22
NPSMSF0808	1/2"	1/2"	22,5	27
NPSMSF1212	3/4"	3/4"	25,0	32
NPSMSF1616	1"	1"	27,0	38
NPSMSF2020	1"1/4	1"1/4	28,0	50

FEMMINA GIREVOLE 90° NPSM CONO 60°
90° NPSM SWIVEL FEMALE 60° CONE
- DKN 90° -

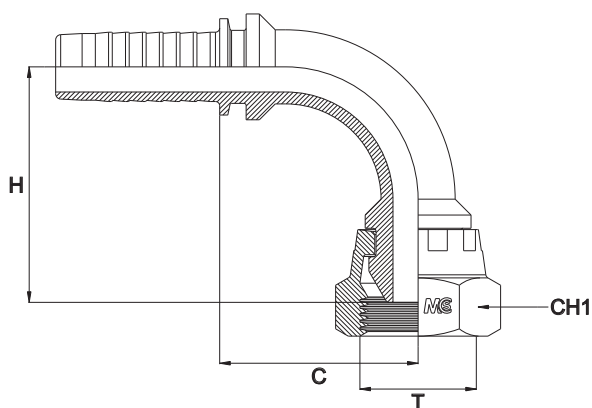

Codice Part Number	Filetto Thread	Ø Int. Tubo Inch. Hose I.D.	C Cut - Off	H Drop	CH1
90NPSMSF0404	1/4"	1/4"	23,5	27,5	19
90NPSMSF0606	3/8"	3/8"	34,5	36,5	22
90NPSMSF0808	1/2"	1/2"	37,5	44,5	27
90NPSMSF1212	3/4"	3/4"	52,5	59,0	32
90NPSMSF1616	1"	1"	67,5	74,5	38

* Disponibile anche a 45°

* Also Available 45°

FEMMINA GIREVOLE A 90° GAS CONO 60 - Compatta
BSP SWIVEL FEMALE 60° CONE - Compact Elbow
- DKR 90° K -

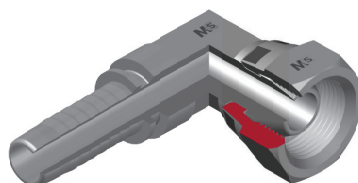
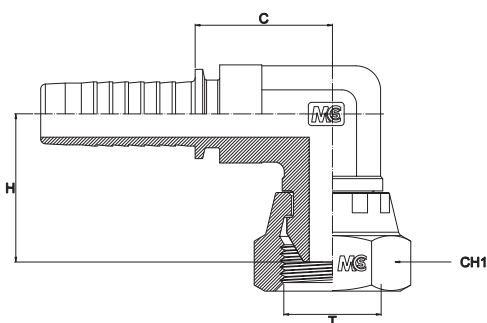

Bar W.P.	Codice Part Number	Filetto Thread	Ø Int. Tubo Inch. Hose I.D.	C Cut - Off	H Drop	CH1
480	90BSPSF0404C	1/4"	1/4"	27,0	25,0	19
	90BSPSF0606C	3/8"	3/8"	25,0	28,2	22
430	90BSPSF0808C	1/2"	1/2"	28,0	30,2	27
	90BSPSF1212C	3/4"	3/4"	25,0	37,0	32
380	90BSPSF1216C	3/4"	1"	31,0	40,0	32
	90BSPSF1616C	1"	1"	31,5	43,5	38

FEMMINA GIREVOLE 90° JIC SVASATA 74°- Compatta
JIC SWIVEL FEMALE 74° CONE- Compact Elbow
- DKJ 90° K -

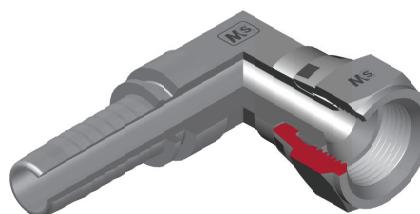
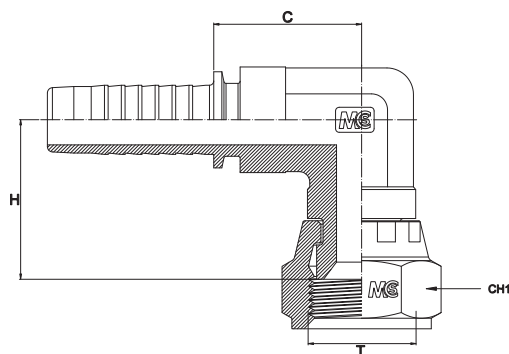

Bar W.P.	Codice Part Number	Filetto Thread	Ø Int. Tubo Inch. Hose I.D.	C Cut - Off	H Drop	CH1
360	90JSF0704C	7/16"	1/4"	27,0	24,3	17
260	90JSF0906C	9/16"	3/8"	25,0	28,2	19
	90JSF1208C	3/4"	1/2"	28,0	30,2	24
210	90JSF1712C	1" 1/16	3/4"	25,0	37,0	32
170	90JSF2116C	1" 5/16	1"	31,5	43,5	38

FEMMINA METRICA TUBOLARE - SERIE LEGGERA/PESANTE
METRIC STANDPIPE - LIGHT/HEAVY TYPE
- BEL/BES -

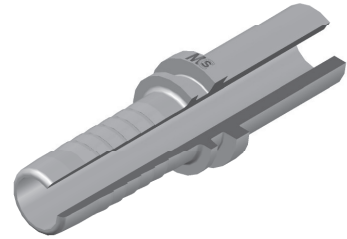
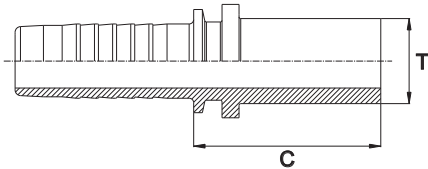

Bar W.P.	Codice Part Number	T Ø Tubo Ø Tube	Ø Int. Tubo Inch. Hose I.D.	C Cut - Off
415	SLH0603	06 L/S	3/16"	29,5
320	SLH0604	06 L/S	1/4"	29,5
415	SLH0803	08 L/S	3/16"	29,5
450	SLH0804	08 L/S	1/4"	29,5
320	SLH0805	08 L/S	5/16"	29,5
350	SLH0806	08 L/S	3/8"	32,0
450	SLH1003	10 L/S	3/16"	29,5
450	SLH1004	10 L/S	1/4"	29,5
350	SLH1005	10 L/S	5/16"	29,5
330	SLH1006	10 L/S	3/8"	32,0
450	SLH1204	12 L/S	1/4"	29,5
350	SLH1205	12 L/S	5/16"	32,0
445	SLH1206	12 L/S	3/8"	32,0
250	SLH1208	12 L/S	1/2"	33,0
445	SH1404	14 S	1/4"	32,0
	SH1406	14 S	3/8"	32,0
415	SH1408	14 S	1/2"	33,0
	SH1608	16 S	1/2"	33,0
215	SH1612	16 S	3/4"	36,0
350	SH2008	20 S	1/2"	33,0
	SH2010	20 S	5/8"	35,5
215	SH2012	20 S	3/4"	36,0
350	SH2512	25 S	3/4"	39,0
165	SH2516	25 S	1"	50,0
250	SH3016	30 S	1"	50,0
210	SH3020	30 S	1" 1/4	57,5
	SH3820	38 S	1" 1/4	57,5
250	SL1506	15 L	3/8"	32,0
	SL1508	15 L	1/2"	33,0
	SL1808	18 L	1/2"	33,0
	SL1810	18 L	5/8"	35,5
160	SL1812	18 L	3/4"	36,0
	SL2210	22 L	5/8"	36,0
	SL2212	22 L	3/4"	36,0
	SL2816	28 L	1"	40,0
100	SL3520	35 L	1" 1/4	47,5
	SL4224	42 L	1" 1/2	48,0

FEMMINA METRICA TUBOLARE 45° - SERIE LEGGERA/PESANTE
45° METRIC STANDPIPE - LIGHT/HEAVY TYPE
- BEL/BES 45° -

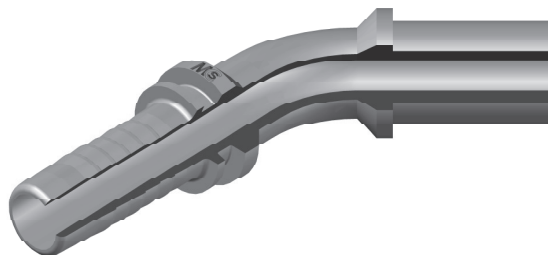
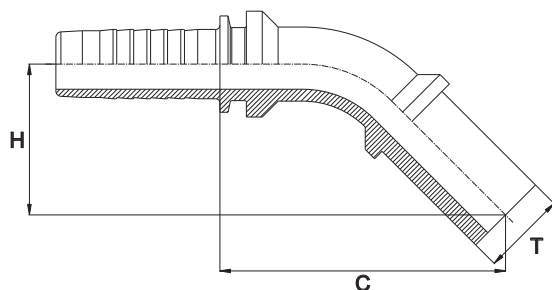

Bar W.P.	Codice Part Number	T Ø Tubo Ø Tube	Ø Int. Tubo Inch. Hose I.D.	C Cut - Off	H Drop
415	45SLH0603	06 L/S	3/16"	48,0	27,5
320	45SLH0604	06 L/S	1/4"	48,5	23,0
415	45SLH0803	08 L/S	3/16"	-	-
450	45SLH0804	08 L/S	1/4"	-	-
320	45SLH0805	08 L/S	5/16"	-	-
350	45SLH1003	10 L/S	3/16"	-	-
450	45SLH1004	10 L/S	1/4"	46,0	23,0
350	45SLH1005	10 L/S	5/16"	-	-
330	45SLH1006	10 L/S	3/8"	63,0	26,0
450	45SLH1204	12 L/S	1/4"	48,5	22,0
350	45SLH1205	12 L/S	5/16"	-	-
445	45SLH1206	12 L/S	3/8"	63,0	26,5
250	45SLH1208	12 L/S	1/2"	74,0	26,5
445	45SH1406	14 S	3/8"	-	-
415	45SH1608	16 S	1/2"	74,5	26,5
350	45SH2010	20 S	5/8"	73,5	33,5
215	45SH2012	20 S	3/4"	-	-
350	45SH2512	25 S	3/4"	-	-
165	45SH2516	25 S	1"	118,2	48,5
250	45SH3016	30 S	1"	-	-
210	45SH3820	38 S	1"1/4	-	-
250	45SL1508	15 L	1/2"	72,0	31,5
160	45SL1808	18 L	1/2"	-	-
	45SL1810	18 L	5/8"	-	-
	45SL2212	22 L	3/4"	-	-
100	45SL2816	28 L	1"	-	-
	45SL3520	35 L	1"1/4	-	-
	45SL4224	42 L	1"1/2	176,5	55,5

FEMMINA METRICA TUBOLARE 90° - SERIE LEGGERA/PESANTE
90° METRIC STANDPIPE - LIGHT/HEAVY TYPE
- BEL/BES 90° -

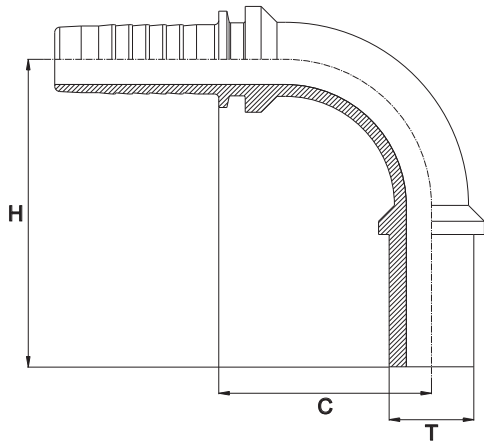

Bar W.P.	Codice Part Number	T Ø Tubo Ø Tube	Ø Int. Tubo Inch. Hose I.D.	C Cut - Off	H Drop
415	90SLH0603	06 L/S	3/16"	23,0	39,0
320	90SLH0604	06 L/S	1/4"	25,0	40,5
415	90SLH0803	08 L/S	3/16"	25,7	40,0
450	90SLH0804	08 L/S	1/4"	25,0	40,5
320	90SLH0805	08 L/S	5/16"	22,5	40,5
350	90SLH1003	10 L/S	3/16"	23,0	39,0
450	90SLH1004	10 L/S	1/4"	24,0	39,0
350	90SLH1005	10 L/S	5/16"	23,5	40,5
330	90SLH1006	10 L/S	3/8"	34,5	47,5
450	90SLH1204	12 L/S	1/4"	23,0	39,5
350	90SLH1205	12 L/S	5/16"	25,5	39,5
445	90SLH1206	12 L/S	3/8"	34,5	46,5
250	90SLH1208	12 L/S	1/2"	37,5	58,0
445	90SH1406	14 S	3/8"	34,5	46,5
415	90SH1608	16 S	1/2"	40,0	56,5
350	90SH2010	20 S	5/8"	38,0	60,0
215	90SH2012	20 S	3/4"	53,0	74,5
350	90SH2512	25 S	3/4"	55,5	70,5
165	90SH2516	25 S	1"	64,5	87,0
250	90SH3016	30 S	1"	66,0	92,0
210	90SH3820	38 S	1" 1/4	-	-
250	90SL1508	15 L	1/2"	40,2	58,1
160	90SL1808	18 L	1/2"	39,5	56,5
	90SL1810	18 L	5/8"	43,5	60,5
	90SL2212	22 L	3/4"	53,5	71,0
100	90SL2816	28 L	1"	90,0	90,5
	90SL3520	35 L	1" 1/4	89,0	111,5
	90SL4224	42 L	1" 1/2	106,5	122,5

FEMMINA TUBOLARE (PER TUBO IN POLLICI) IMPERIAL STANDPIPE

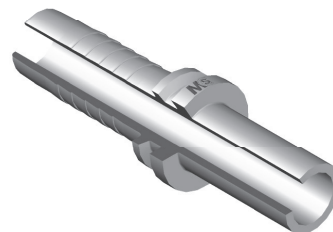
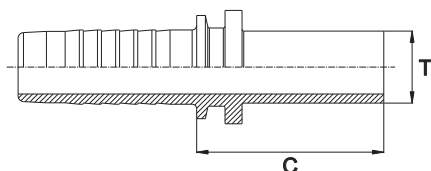

Bar W.P.	Codice Part Number	T Ø Tubo Ø Tube	Ø Int. Tubo Inch. Hose I.D.	C Cut - Off
450	IS0404	1/4" - 6,35 mm	1/4"	29,5
	IS0505	5/16" - 7,94 mm	5/16"	29,5
350	IS0604	3/8" - 9,52 mm	1/4"	32,0
	IS0605	3/8" - 9,52 mm	5/16"	32,0
420	IS0606	3/8" - 9,52 mm	3/8"	32,0
	IS0806	1/2" - 12,70 mm	3/8"	32,0
250	IS0808	1/2" - 12,70 mm	1/2"	33,0
160	IS1008	5/8" - 15,88 mm	1/2"	33,0
160	IS1010	5/8" - 15,88 mm	5/8"	33,0
215	IS1208	3/4" - 19,05 mm	1/2"	33,0
	IS1212	3/4" - 19,05 mm	3/4"	36,0
350	IS1612	1" - 25,40 mm	3/4"	39,0
165	IS1616	1" - 25,40 mm	1"	40,0
210	IS2020	1"1/4 - 31,75 mm	1"1/4	47,5
170	IS2424	1"1/2 - 38,10 mm	1"1/2	48,0

* Disponibile anche a 45° e 90°

* Also Available 45° & 90°

FEMMINA TUBOLARE DOPPIA ESTREMITÀ DOUBLE HOSE STANDPIPE

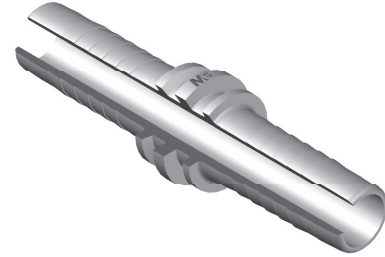
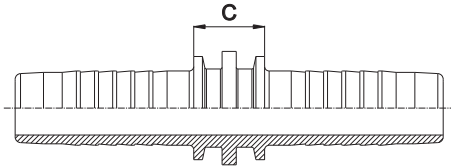

Bar W.P.	Codice Part Number	Ø Int. Tubo Inch. Hose I.D.	C Cut - Off
450	DHS04	1/4"	12,5
350	DHS05	5/16"	12,5
445	DHS06	3/8"	12,5
415	DHS08	1/2"	12,5
350	DHS10	5/8"	17,0
	DHS12	3/4"	14,5
280	DHS16	1"	17,0
210	DHS20	1"1/4"	19,0
185	DHS24	1"1/2"	20,0
165	DHS32	2"	21,0
120	DHS40	2"½	24,0
70	DHS48	3"	28,0

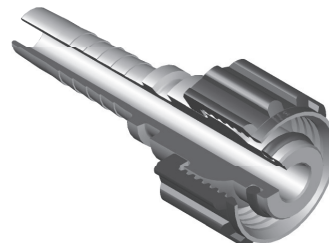
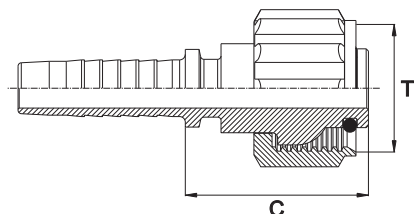
FEMMINA PER IDROPULITRICI**K' FEMALE****- DADO IN ACCIAIO INOX - STAINLESS STEEL NUT -****- DKO-KA -**

Bar W.P.	Codice Part Number	Filetto Thread	Ø Int. Tubo Inch. Hose I.D.	C Cut - Off
450	KF2204	22x1,5	1/4"	34,5
350	KF2205	22x1,5	5/16"	35,5
315	KF2206	22x1,5	3/8"	35,5
315	KF2208	22x1,5	1/2"	35,5

MASCHIO SVASATO A 60°

Filetto Gas Cilindrico

MALE 60° CONE

Thread BSP Parallel

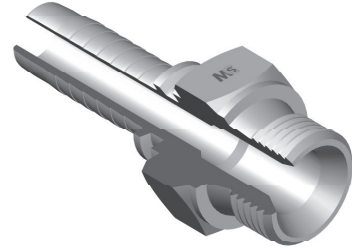
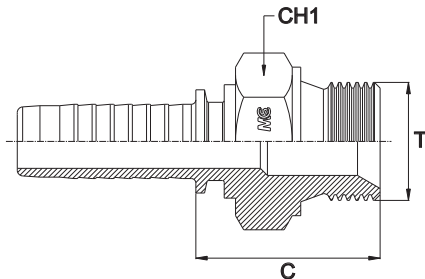
- AGR -

Bar W.P.	Codice Part Number	Filetto Thread	Ø Int. Tubo Inch. Hose I.D.	C Cut - Off	CH1
415	BSPM0202	1/8"	1/8"	24,0	14
	BSPM0203	1/8"	3/16"	24,5	14
	BSPM0204	1/8"	1/4"	23,5	14
	BSPM0205	1/8"	5/16"	24,5	14
	BSPM0206	1/8"	3/8"	25,0	17
	BSPM0403	1/4"	3/16"	27,0	19
450	BSPM0404	1/4"	1/4"	27,0	19
350	BSPM0405	1/4"	5/16"	27,0	19
450	BSPM0406	1/4"	3/8"	27,0	19
415	BSPM0408	1/4"	1/2"	28,0	19
450	BSPM0604	3/8"	1/4"	29,0	22
350	BSPM0605	3/8"	5/16"	29,0	22
450	BSPM0606	3/8"	3/8"	29,0	22
415	BSPM0608	3/8"	1/2"	29,5	22
450	BSPM0804	1/2"	1/4"	32,0	27
350	BSPM0805	1/2"	5/16"	32,0	27
450	BSPM0806	1/2"	3/8"	32,0	27
415	BSPM0808	1/2"	1/2"	32,5	27
350	BSPM0810	1/2"	5/8"	34,0	27
	BSPM0812	1/2"	3/4"	33,0	27
415	BSPM1008	5/8"	1/2"	33,5	30
350	BSPM1010	5/8"	5/8"	35,0	30
415	BSPM1208	3/4"	1/2"	35,5	32
350	BSPM1210	3/4"	5/8"	37,0	32
	BSPM1212	3/4"	3/4"	36,5	32
280	BSPM1216	3/4"	1"	37,5	32
350	BSPM1612	1"	3/4"	40,5	38
280	BSPM1616	1"	1"	41,5	38
	BSPM2016	1" 1/4	1"	45,5	50
210	BSPM2020	1" 1/4	1" 1/4	46,0	50
185	BSPM2024	1" 1/4	1" 1/2	46,5	50
210	BSPM2420	1" 1/2	1" 1/4	46,0	55
185	BSPM2424	1" 1/2	1" 1/2	46,5	55
165	BSPM3232	2"	2"	50,0	70
120	BSPM4032	2" 1/2	2"	54,0	80
	BSPM4040	2" 1/2	2" 1/2	56,5	80
70	BSPM4848	3"	3"	57,0	100

MASCHIO SEDE PIANA

Filetto Gas Cilindrico

MALE FLAT SEAT

Thread BSP Parallel

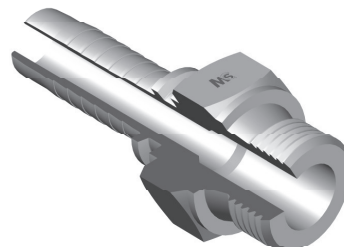
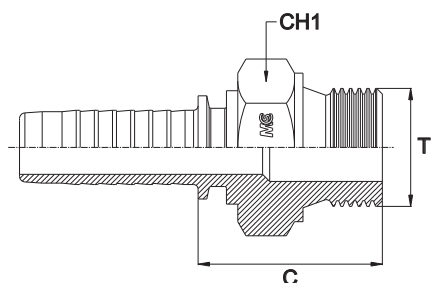
- AGR- F -

Bar W.P.	Codice Part Number	Filetto Thread	Ø Int. Tubo Inch. Hose I.D.	C Cut - Off	CH1
450	BSPMFS0404	1/4"	1/4"	27,0	19,0
350	BSPMFS0605	3/8"	5/16"	29,0	22,0
450	BSPMFS0606	3/8"	3/8"	29,0	22,0
	BSPMFS0806	1/2"	3/8"	32,0	27,0
415	BSPMFS0808	1/2"	1/2"	32,5	27,0
	BSPMFS1008	5/8"	1/2"	33,0	30,0
350	BSPMFS1010	5/8"	5/8"	35,0	30,0
415	BSPMFS1208	3/4"	1/2"	35,5	32,0
	BSPMFS1210	3/4"	5/8"	37,0	32,0
	BSPMFS1212	3/4"	3/4"	36,5	32,0
280	BSPMFS1612	1"	3/4"	40,5	38,0
	BSPMFS1616	1"	1"	41,5	38,0
210	BSPMFS2016	1" 1/4	1"	45,5	50,0
	BSPMFS2020	1" 1/4	1" 1/4	46,0	50,0
184	BSPMFS2420	1" 1/2	1" 1/4	46,0	55,0
	BSPMFS2424	1" 1/2	1" 1/2	46,5	55,0
165	BSPMFS3232	2"	2"	50,0	70,0

MASCHIO METRICO SVASATO 24° - SERIE LEGGERA
METRIC MALE 24° CONE - LIGHT TYPE
- CEL -

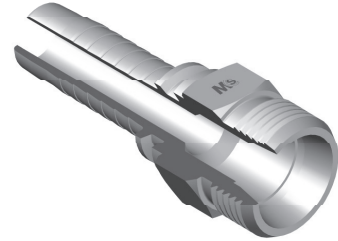
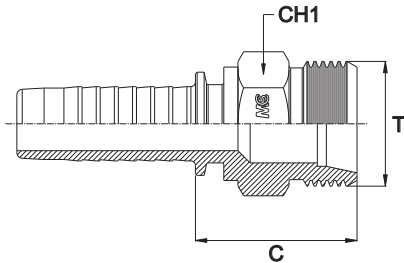

Bar W.P.	Codice Part Number	Filetto Thread	Ø Int. Tubo Inch. Hose I.D.	DIN 24°	C Cut - Off	CH1
280	MML0603	12x1,5	3/16"	06L	25,0	14
	MML0604	12x1,5	1/4"	06L	25,0	14
	MML0803	14x1,5	3/16"	08L	25,0	14
	MML0804	14x1,5	1/4"	08L	25,0	14
	MML1004	16x1,5	1/4"	10L	27,0	17
	MML1005	16x1,5	5/16"	10L	27,0	17
	MML1006	16x1,5	3/8"	10L	27,0	17
	MML1204	18x1,5	1/4"	12L	27,0	19
	MML1205	18x1,5	5/16"	12L	27,0	19
	MML1206	18x1,5	3/8"	12L	27,0	19
	MML1208	18x1,5	1/2"	12L	27,0	19
210	MML1506	22x1,5	3/8"	15L	28,5	22
	MML1508	22x1,5	1/2"	15L	28,5	22
	MML1808	26x1,5	1/2"	18L	31,0	27
	MML1810	26x1,5	5/8"	18L	31,0	27
	MML1812	26x1,5	3/4"	18L	30,5	27
165	MML2210	30x2	5/8"	22L	32,5	30
	MML2212	30x2	3/4"	22L	32,5	30
100	MML2816	36x2	1"	28L	35,5	36
125	MML3520	45x2	1,1/4"	35L	39,0	46
100	MML4224	52x2	1,1/2"	42L	40,5	55

MASCHIO METRICO SVASATO 24° - SERIE PESANTE
METRIC MALE 24° CONE - HEAVY TYPE
- CES -

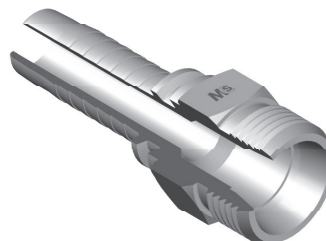
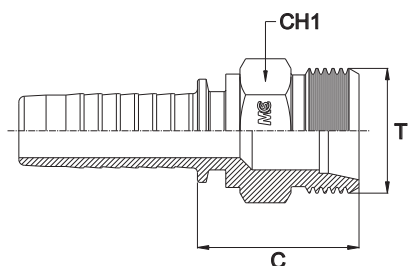

Bar W.P.	Codice Part Number	Filetto Thread	Ø Int. Tubo Inch. Hose I.D.	DIN 24°	C Cut - Off	CH1
450	MMH0604	14x1,5	1/4"	06S	27,5	14
	MMH0804	16x1,5	1/4"	08S	28,0	17
	MMH1004	18x1,5	1/4"	10S	27,0	19
350	MMH1005	18x1,5	5/16"	10S	27,0	19
450	MMH1006	18x1,5	3/8"	10S	27,0	19
	MMH1204	20x1,5	1/4"	12S	28,0	22
350	MMH1205	20x1,5	5/16"	12S	28,0	22
450	MMH1206	20x1,5	3/8"	12S	28,0	22
350	MMH1405	22x1,5	5/16"	14S	29,5	22
450	MMH1406	22x1,5	3/8"	14S	29,5	24
420	MMH1606	24x1,5	3/8"	16S	31,0	24
	MMH1608	24x1,5	1/2"	16S	31,0	24
350	MMH1610	24x1,5	5/8"	16S	32,5	24
280	MMH1616	24x1,5	1"	16S	32,0	36
350	MMH2008	30x2	1/2"	20S	33,5	30
	MMH2010	30x2	5/8"	20S	35,0	30
	MMH2012	30x2	3/4"	20S	35,0	30
	MMH2512	36x2	3/4"	25S	37,5	36
280	MMH2516	36x2	1"	25S	38,5	36
350	MMH3008	42x2	1/2"	30S	41,5	46
280	MMH3016	42x2	1"	30S	42,5	46
210	MMH3020	42x2	1" 1/4	30S	43,5	46
280	MMH3816	52x2	1"	38S	45,0	55
210	MMH3820	52x2	1" 1/4	38S	46,0	55

MASCHIO SVASATO 60°

Filetto Gas Conico

MALE 60° CONE

Thread BSP Taper

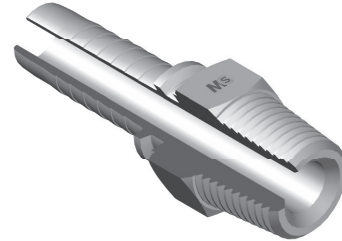
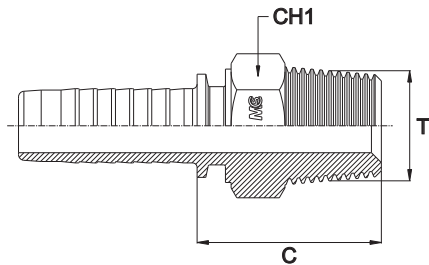
- AGR-K -

Bar W.P.	Codice Part Number	Filetto Thread	Ø Int. Tubo Inch. Hose I.D.	C Cut - Off	CH1
415	BSPTM0203	1/8"	3/16"	22,5	14
450	BSPTM0204	1/8"	1/4"	22,5	14
415	BSPTM0403	1/4"	3/16"	26,7	14
450	BSPTM0404	1/4"	1/4"	27,0	14
350	BSPTM0405	1/4"	5/16"	27,5	14
450	BSPTM0406	1/4"	3/8"	27,3	17
	BSPTM0604	3/8"	1/4"	28,6	19
350	BSPTM0605	3/8"	5/16"	29,0	19
450	BSPTM0606	3/8"	3/8"	29,5	19
415	BSPTM0608	3/8"	1/2"	29,0	19
350	BSPTM0610	3/8"	5/8"	29,5	22
	BSPTM0804	1/2"	1/4"	32,0	22
415	BSPTM0806	1/2"	3/8"	33,0	22
	BSPTM0808	1/2"	1/2"	32,5	22
	BSPTM0810	1/2"	5/8"	28,5	22
	BSPTM0812	1/2"	3/4"	36,5	27
350	BSPTM1208	3/4"	1/2"	35,0	27
	BSPTM1210	3/4"	5/8"	36,3	27
	BSPTM1212	3/4"	3/4"	36,5	27
	BSPTM1216	3/4"	1"	37,5	32
280	BSPTM1612	1"	3/4"	43,5	36
	BSPTM1616	1"	1"	44,5	36
	BSPTM1620	1"	1"1/4	47,0	41
210	BSPTM2016	1"1/4	1"	47,0	46
	BSPTM2020	1"1/4	1"1/4	48,0	46
185	BSPTM2424	1"1/2	1"1/2	46,0	50
165	BSPTM3232	2"	2"	49,0	65

MASCHIO SVASATO 60°

Filetto NPT

MALE 60° CONE

Thread NPT

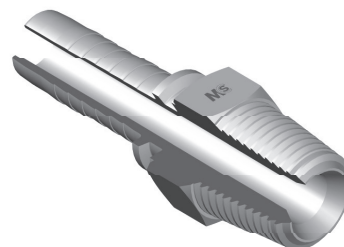
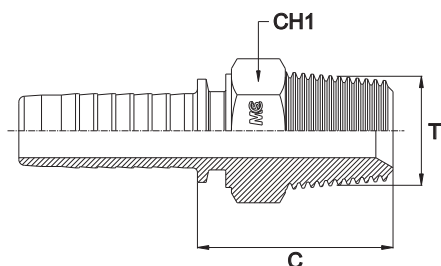
- AGN -

Bar W.P.	Codice Part Number	Filetto Thread	Ø Int. Tubo Inch. Hose I.D.	C Cut - Off	CH1
415	NPTM0203	1/8"	3/16"	24,5	14
450	NPTM0204	1/8"	1/4"	24,5	14
415	NPTM0403	1/4"	3/16"	29,1	14
450	NPTM0404	1/4"	1/4"	27,5	14
350	NPTM0405	1/4"	5/16"	28,5	14
450	NPTM0406	1/4"	3/8"	29,3	17
350	NPTM0604	3/8"	1/4"	29,0	19
350	NPTM0605	3/8"	5/16"	29,3	19
450	NPTM0606	3/8"	3/8"	29,3	19
415	NPTM0608	3/8"	1/2"	29,0	19
350	NPTM0610	3/8"	5/8"	34,3	22
415	NPTM0804	1/2"	1/4"	34,6	22
415	NPTM0806	1/2"	3/8"	35,1	22
415	NPTM0808	1/2"	1/2"	34,5	22
350	NPTM0810	1/2"	5/8"	39,4	22
350	NPTM0812	1/2"	3/4"	38,1	27
350	NPTM1208	3/4"	1/2"	35,0	27
350	NPTM1210	3/4"	5/8"	36,0	27
350	NPTM1212	3/4"	3/4"	36,5	27
280	NPTM1216	3/4"	1"	37,5	32
280	NPTM1612	1"	3/4"	43,5	36
280	NPTM1616	1"	1"	44,5	36
210	NPTM1620	1"	1"1/4"	47,0	41
210	NPTM2016	1"1/4"	1"	47,0	46
210	NPTM2020	1"1/4"	1"1/4"	48,0	46
185	NPTM2424	1"1/2"	1"1/2"	49,0	50
165	NPTM3232	2"	2"	50,0	65

MASCHIO JIC CONO 74°
JIC MALE 74° CONE
- AGJ -

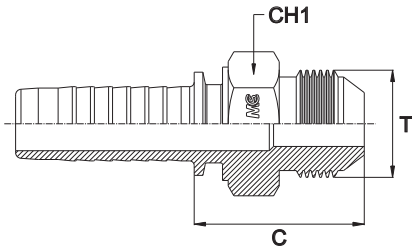

Bar W.P.	Codice Part Number	Filetto Thread	Ø Int. Tubo Inch. Hose I.D.	C Cut - Off	CH1
415	JM0703	7/16"	3/16"	28,1	14
	JM0704	7/16"	1/4"	27,5	14
450	JM0804	1/2"	1/4"	28,5	14
	JM0904	9/16"	1/4"	28,0	17
350	JM0905	9/16"	5/16"	27,9	17
450	JM0906	9/16"	3/8"	28,3	17
415	JM1206	3/4"	3/8"	30,5	22
	JM1208	3/4"	1/2"	30,0	22
350	JM1406	7/8"	3/8"	35,3	24
	JM1408	7/8"	1/2"	36,0	24
	JM1410	7/8"	5/8"	37,7	24
	JM1412	7/8"	3/4"	36,5	27
	JM1708	1" 1/16	1/2"	38,0	27
	JM1710	1" 1/16	5/8"	39,0	27
	JM1712	1" 1/16	3/4"	39,5	27
280	JM1716	1" 1/16	1"	42,5	32
	JM2112	1" 5/16	3/4"	41,0	36
	JM2116	1" 5/16	1"	43,8	36
	JM2616	1" 5/8	1"	45,5	46
210	JM2620	1" 5/8	1" 1/4	46,5	46
	JM3016	1" 7/8	1"	50,0	50
140	JM3020	1" 7/8	1" 1/4	51,0	50
	JM3024	1" 7/8	1" 1/2	51,5	50
105	JM4032	2" 1/2	2"	-	65

FLANGIA SAE SERIE 3000 PSI
SAE STRAIGHT FLANGE 3000 PSI
- SFL -

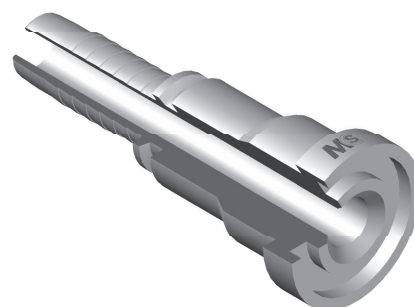
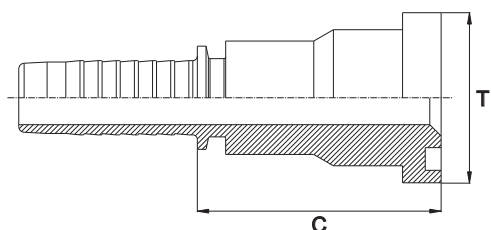

Bar W.P.	Codice Part Number	Flangia Flange	Ø Int. Tubo Inch. Hose I.D.	T	C Cut - Off
350	SSF30000808	1/2"	1/2"	30,2	43,0
	SSF30001208	3/4"	1/2"	38,1	47,0
	SSF30001210	3/4"	5/8"	38,1	48,5
	SSF30001212	3/4"	3/4"	38,1	47,5
	SSF30001610	1"	5/8"	44,5	54,5
	SSF30001612	1"	3/4"	44,5	53,5
280	SSF30001616	1"	1"	44,5	54,5
	SSF30002016	1" 1/4	1"	50,8	56,5
210	SSF30002020	1" 1/4	1" 1/4	50,8	57,5
280	SSF30002416	1" 1/2	1"	60,3	56,5
210	SSF30002420	1" 1/2	1" 1/4	60,3	62,5
185	SSF30002424	1" 1/2	1" 1/2	60,3	63,0
-	SSF30003224*	2"	1" 1/2	71,4	50,5
170	SSF30003232	2"	2"	71,4	63,0
-	SSF30004032*	2" 1/2	2"	84,1	58,0
140	SSF30004040	2" 1/2	2" 1/2	84,1	60,0
90	SSF30004848	3"	3"	101,5	132,0

* Saldata

* Welded

FLANGIA SAE SERIE 6000 PSI
SAE STRAIGHT FLANGE 6000 PSI
- SFS -

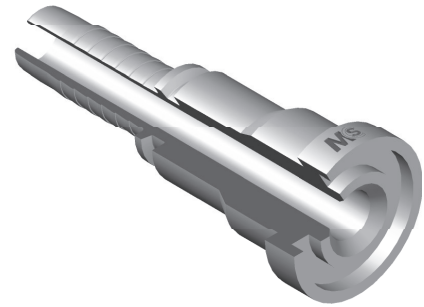
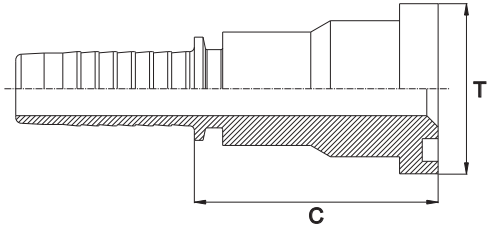

Bar W.P.	Codice Part Number	Flangia Flange	Ø Int. Tubo Inch. Hose I.D.	T	C Cut - Off
415	SSF60000808	1/2"	1/2"	31,7	43,0
	SSF60001208	3/4"	1/2"	41,3	53,0
350	SSF60001210	3/4"	5/8"	41,3	54,5
	SSF60001212	3/4"	3/4"	41,3	53,5
	SSF60001610	1"	5/8"	47,6	59,5
	SSF60001612	1"	3/4"	47,6	58,5
280	SSF60001616	1"	1"	47,6	59,5
	SSF60002016	1,1/4"	1"	54,0	66,5
210	SSF60002020	1,1/4"	1,1/4"	54,0	67,5
280	SSF60002416	1" 1/2	1"	-	72,5
210	SSF60002420	1" 1/2	1" 1/4	63,5	72,5
185	SSF60002424	1" 1/2	1" 1/2	63,5	73,0
172	SSF60003224*	2"	1" 1/2	79,4	-
	SSF60003232	2"	2"	79,4	68,0

* Saldata

* Welded

FLANGIA 45° SAE SERIE 3000 PSI
45° SAE FLANGE 3000 PSI
- SFL 45° -

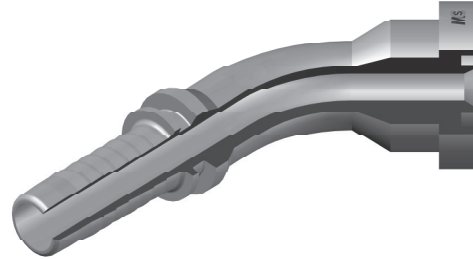
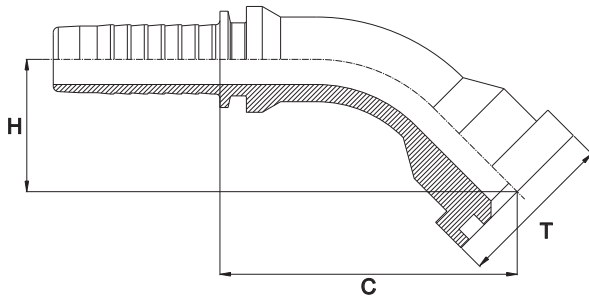

Bar W.P.	Codice Part Number	Flangia Flange	Ø Int. Tubo Inch. Hose I.D.	T	C Cut - Off	H Drop
350	45SF30000808	1/2"	1/2"	30,2	63,5	23,0
	45SF30001208	3/4"	1/2"	38,1	65,7	24,0
	45SF30001210	3/4"	5/8"	38,1	69,0	37,0
	45SF30001212	3/4"	3/4"	38,1	81,0	31,0
	45SF30001612	1"	3/4"	44,5	81,5	31,5
280	45SF30001616	1"	1"	44,5	102,5	32,0
	45SF30002016	1"1/4	1"	50,8	-	-
210	45SF30002020	1"1/4	1"1/4	50,8	132,5	39,0
	45SF30002420	1"1/2	1"1/4	60,3	-	-
185	45SF30002424	1"1/2	1"1/2	60,3	171,0	46,0
-	45SF30003224*	2"	1"1/2	71,4	-	-
170	45SF30003232	2"	2"	71,4	-	-
-	45SF30004040*	2"1/2	2"1/2	84,1	-	-

* Saldata

* Welded

FLANGIA 45° SAE SERIE 6000 PSI
45° SAE FLANGE 6000 PSI
- SFS 45° -

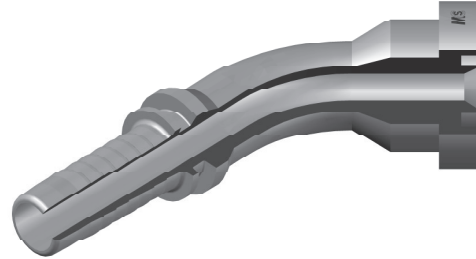
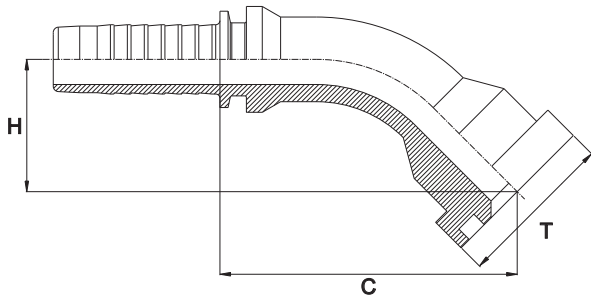

Bar W.P.	Codice Part Number	Flangia Flange	Ø Int. Tubo Inch. Hose I.D.	T	C Cut - Off	H Drop
415	45SF60000808	1/2"	1/2"	31,7	67,0	25,0
	45SF60001208	3/4"	1/2"	41,3	-	-
350	45SF60001212	3/4"	3/4"	41,3	83,5	31,0
	45SF60001612	1"	3/4"	47,6	-	-
280	45SF60001616	1"	1"	47,6	-	-
	45SF60002016	1"1/4	1"	54,0	-	-
210	45SF60002020	1"1/4	1"1/4	54,0	128,5	36,0
	45SF60002420	1"1/2	1"1/4	63,5	-	-
185	45SF60002424	1"1/2	1"1/2	63,5	-	-
-	45SF60003224*	2"	1"1/2	79,4	-	-
172	45SF60003232	2"	2"	79,4	-	-

* Saldata

* Welded

FLANGIA 90° SAE SERIE 3000 PSI
90° SAE FLANGE 3000 PSI
- SFL 90° -

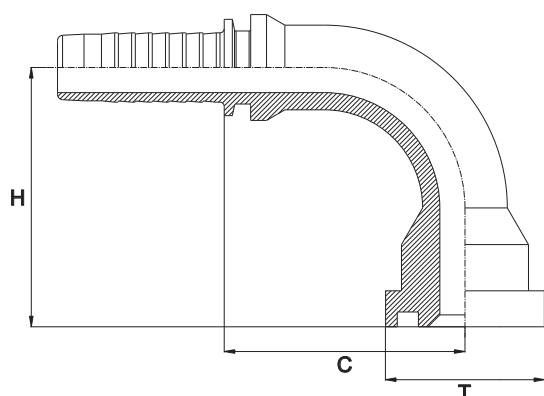

Bar W.P.	Codice Part Number	Flangia Flange	Ø Int. Tubo Inch. Hose I.D.	T	C Cut - Off	H Drop
350	90SF30000808	1/2"	1/2"	30,2	41,0	50,5
	90SF30001208	3/4"	1/2"	38,1	-	-
	90SF30001210	3/4"	5/8"	38,1	58,0	52,0
	90SF30001212	3/4"	3/4"	38,1	51,0	61,5
	90SF30001612	1"	3/4"	44,5	50,0	65,0
280	90SF30001616	1"	1"	44,5	65,0	70,5
	90SF30002016	1" 1/4	1"	50,8	69,8	86,2
210	90SF30002020	1" 1/4	1" 1/4	50,8	83,0	95,0
	90SF30002420	1" 1/2	1" 1/4	60,3	84,2	99,0
185	90SF30002424	1" 1/2	1" 1/2	60,3	113,0	110,0
-	90SF30003224*	2"	1" 1/2	71,4	116,5	124,0
170	90SF30003232	2"	2"	71,4	-	-
90	90SF30004040*	2" 1/2	2" 1/2	84,1	90,0	110,0
90	90SF30004848*	3"	3"	101,5	108,0	130,5

* Saldata

* Welded

FLANGIA 90° SAE SERIE 6000 PSI
90° SAE FLANGE 6000 PSI
- SFS 90° -

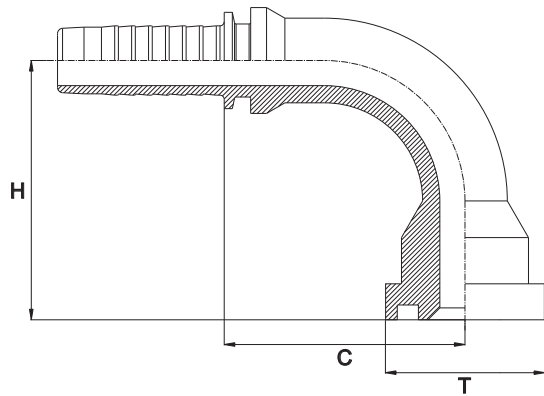

Bar W.P.	Codice Part Number	Flangia Flange	Ø Int. Tubo Inch. Hose I.D.	T	C Cut - Off	H Drop
415	90SF60000808	1/2"	1/2"	31,7	38,5	50,0
	90SF60001208	3/4"	1/2"	41,3	39,0	47,5
350	90SF60001212	3/4"	3/4"	41,3	49,0	63,0
	90SF60001612	1"	3/4"	47,6	51,5	59,5
280	90SF60001616	1"	1"	47,6	62,0	76,0
	90SF60002016	1" 1/4	1"	54,0	71,5	86,0
210	90SF60002020	1" 1/4	1" 1/4	54,0	82,0	95,0
	90SF60002420	1" 1/2	1" 1/4	63,5	-	-
185	90SF60002424	1" 1/2	1" 1/2	63,5	111,0	118,0
-	90SF60003224*	2"	1" 1/2	79,4	-	-
172	90SF60003232	2"	2"	79,4	121,0	128,0

* Saldata

* Welded

SEMI FLANGIA TAGLIATA SAE 3000 SPLIT FLANGE SAE 3000 - CUT

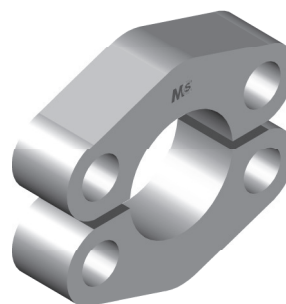
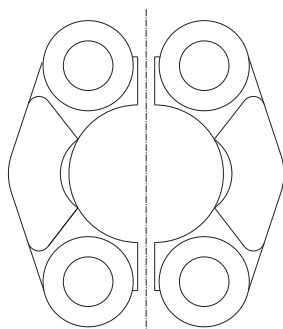

Codice Part Number	Per Flangia Da: For Flange By:
SF300008	1/2"
SF300012	3/4"
SF300016	1"
SF300020	1" 1/4
SF300024	1" 1/2
SF300032	2"

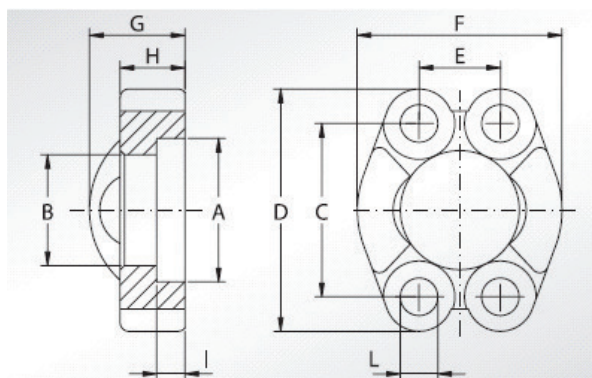

DIMENSIONI TECNICHE - TECHNICAL DATA											
CODICE PART	maximum Kg/cm ²	A MM	B MM	C MM	D MM	E MM	F MM	G MM	H MM	I MM	L MM
SF300008	345	30,96	24,26	38,10	54,0	17,48	45,60	19,00	13,00	6,22	8,75
SF300012	345	38,89	32,13	47,63	65,0	22,23	51,80	22,00	14,00	6,22	10,75
SF300016	345	45,24	38,48	52,37	70,0	26,19	58,40	24,00	16,00	7,49	10,75
SF300020	276	51,59	43,69	58,72	79,0	30,18	72,60	22,00	14,00	7,49	12,00
SF300024	207	61,09	50,80	69,85	94,0	35,71	82,20	25,00	16,00	7,49	13,50
SF300032	207	72,24	62,74	77,77	102,0	42,88	96,40	26,00	16,00	9,02	13,50

SEMI FLANGIA TAGLIATA SAE 6000

SPLIT FLANGE SAE 6000 - CUT

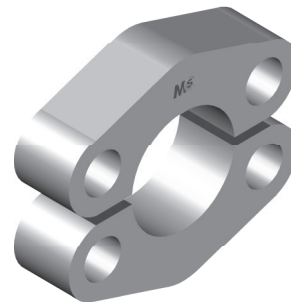
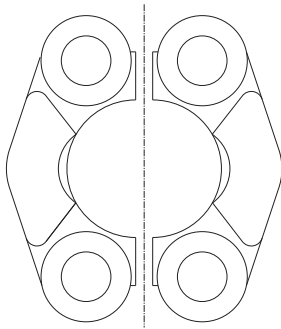

Codice Part Number	Per Flangia Da: For Flange By:
SF600008	1/2"
SF600012	3/4"
SF600016	1"
SF600020	1" 1/4
SF600024	1" 1/2
SF600032	2"

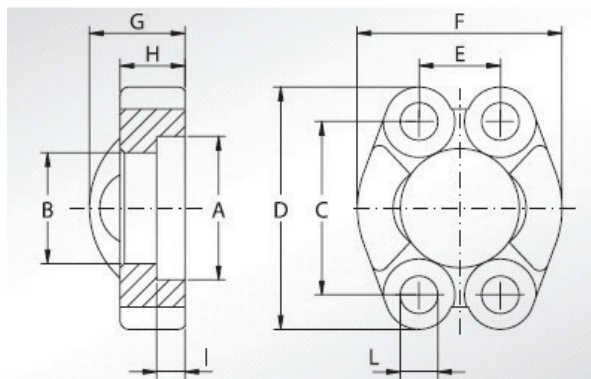

DIMENSIONI TECNICHE - TECHNICAL DATA											
CODICE	maximum	A	B	C	D	E	F	G	H	I	L
PART	Kg/cm ²	MM	MM	MM	MM	MM	MM	MM	MM	MM	MM
SF600008	414	32.54	24.64	40.49	56.0	18.24	47.20	22.00	16.00	7.24	8.75
SF600012	414	42.06	32.51	50.80	71.0	23.80	60.00	28.00	19.00	8.26	11.00
SF600016	414	48.41	38.86	57.15	81.0	27.76	69.60	33.00	24.00	9.02	13.00
SF600020	414	54.76	44.45	66.68	95.0	31.75	77.20	38.00	27.00	9.78	15.00
SF600024	414	64.29	51.56	79.38	113.0	36.50	95.00	43.00	30.00	12.07	17.00
SF600032	414	80.16	67.56	96.82	133.0	44.45	113.80	52.00	37.00	12.07	21.00

SEMI FLANGIA INTERA SAE 3000 SPLIT FLANGE SAE 3000 - UNCUT

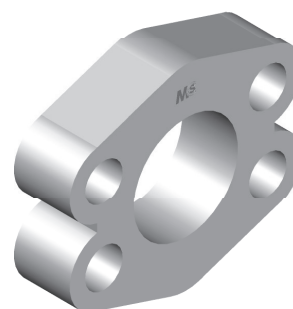
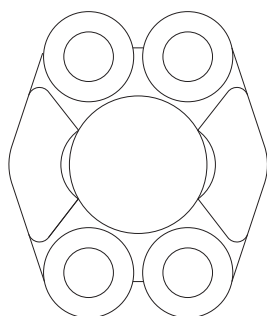

Codice Part Number	Per Flangia Da: For Flange By:
USF300008	1/2"
USF300012	3/4"
USF300016	1"
USF300020	1" 1/4
USF300024	1" 1/2
USF300032	2"

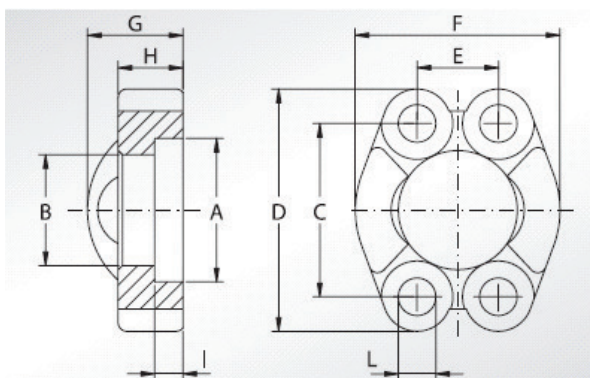

DIMENSIONI TECNICHE - TECHNICAL DATA											
CODICE	maximum	A	B	C	D	E	F	G	H	I	L
PART	Kg/cm2	MM	MM	MM	MM	MM	MM	MM	MM	MM	MM
USF300008	345	30,96	24,26	38,10	54,0	17,48	45,60	19,00	13,00	6,22	8,75
USF300012	345	38,89	32,13	47,63	65,0	22,23	51,80	22,00	14,00	6,22	10,75
USF300016	345	45,24	38,48	52,37	70,0	26,19	58,40	24,00	16,00	7,49	10,75
USF300020	276	51,59	43,69	58,72	79,0	30,18	72,60	22,00	14,00	7,49	12,00
USF300024	207	61,09	50,80	69,85	94,0	35,71	82,20	25,00	16,00	7,49	13,50
USF300032	207	72,24	62,74	77,77	102,0	42,88	96,40	26,00	16,00	9,02	13,50

SEMI FLANGIA INTERA SAE 6000 SPLIT FLANGE SAE 6000 - UNCUT

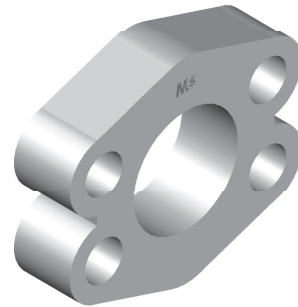
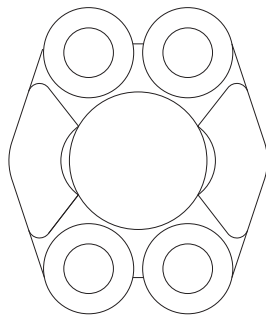

Codice Part Number	Per Flangia Da: For Flange By:
USF600008	1/2"
USF600012	3/4"
USF600016	1"
USF600020	1" 1/4
USF600024	1" 1/2
USF600032	2"

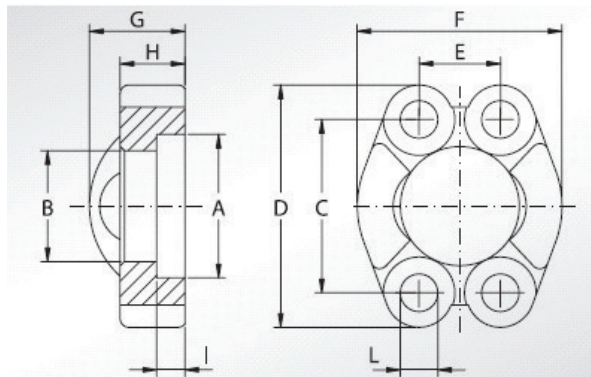

DIMENSIONI TECNICHE - TECHNICAL DATA											
CODICE	maximum	A	B	C	D	E	F	G	H	I	L
PART	Kg/cm ²	MM	MM	MM	MM	MM	MM	MM	MM	MM	MM
USF600008	414	32,54	24,64	40,49	56,0	18,24	47,20	22,00	16,00	7,24	8,75
USF600012	414	42,06	32,51	50,80	71,0	23,80	60,00	28,00	19,00	8,26	11,00
USF600016	414	48,41	38,86	57,15	81,0	27,76	69,60	33,00	24,00	9,02	13,00
USF600020	414	54,76	44,45	66,68	95,0	31,75	77,20	38,00	27,00	9,78	15,00
USF600024	414	64,29	51,56	79,38	113,0	36,50	95,00	43,00	30,00	12,07	17,00
USF600032	414	80,16	67,56	96,82	133,0	44,45	113,80	52,00	37,00	12,07	21,00

OCCHIO GAS
BSP BANJO
- RNR -

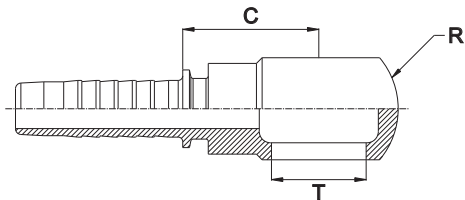

Bar W.P.	Codice Part Number	Filetto Thread	Ø Int. Tubo Inch. Hose I.D.	R	C Cut - Off
300	BSPBJ0403	1/4"	3/16"	24,0	24,0
	BSPBJ0404	1/4"	1/4"	24,0	24,0
	BSPBJ0604	3/8"	1/4"	28,0	24,0
	BSPBJ0605	3/8"	5/16"	28,0	24,5
280	BSPBJ0606	3/8"	3/8"	28,0	24,0
	BSPBJ0804	1/2"	1/4"	38,0	27,5
200	BSPBJ0806	1/2"	3/8"	38,0	27,5
	BSPBJ0808	1/2"	1/2"	38,0	28,0
120	BSPBJ1212	3/4"	3/4"	45,0	38,5
	BSPBJ1616	1"	1"	58,0	51,5

OCCHIO METRICO
METRIC BANJO
- RNM -

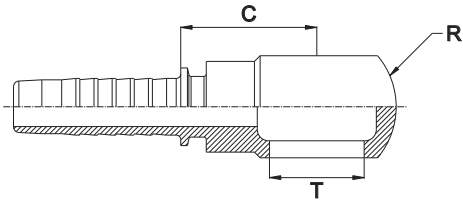

Bar W.P.	Codice Part Number	Filetto Thread	Ø Int. Tubo Inch. Hose I.D.	R	C Cut - Off
300	MBJ1204	12x1,5	1/4"	20,0	24,0
	MBJ1404	14x1,5	1/4"	24,0	24,0
	MBJ1405	14x1,5	5/16"	24,0	24,0
280	MBJ1406	14x1,5	3/8"	24,0	24,0
300	MBJ1605	16x1,5	5/16"	28,0	24,5
280	MBJ1606	16x1,5	3/8"	28,0	24,0
	MBJ1806	18x1,5	3/8"	32,0	24,0
250	MBJ1808	18x1,5	1/2"	32,0	28,0
200	MBJ2208	22x1,5	1/2"	36,0	28,0
	MBJ2612	26x1,5	3/4"	45,0	38,5
120	MBJ3012	30x1,5	3/4"	54,0	38,5

VITE CAVA PER OCCHIO GAS BSP BOLT FOR BANJO

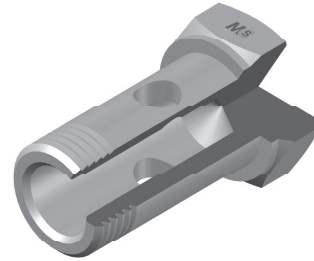
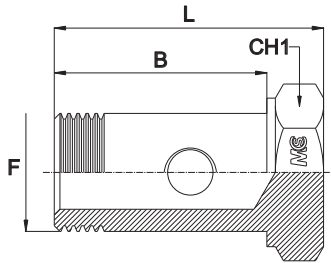

Bar W.P.	Codice Part Number	Filetto Thread	B	L	CH1
350	BSPBLT02	1/8"	23,0	30,0	14
300	BSPBLT04	1/4"	27,5	34,5	19
280	BSPBLT06	3/8"	31,0	40,0	22
200	BSPBLT08	1/2"	37,5	47,5	27
	BSPBLT12	3/4"	47,0	59,0	32
120	BSPBLT16	1"	58,0	70,0	41
105	BSPBLT20	1"1/4	-	-	50

VITE CAVA PER OCCHIO METRICO METRIC BOLT FOR BANJO

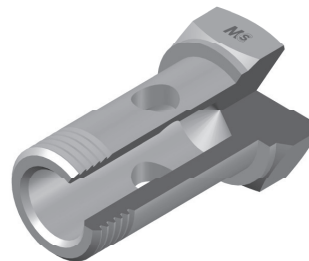
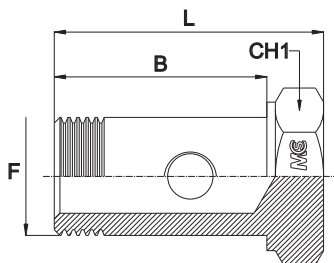

Bar W.P.	Codice Part Number	Filetto Thread	B	L	CH1
300	MBLT12	12x1,5	24,0	31,0	17
	MBLT14	14x1,5	31,0	40,0	19
250	MBLT16	16x1,5	31,0	40,0	22
	MBLT18	18x1,5	36,0	45,0	24
200	MBLT22	22x1,5	-	-	27
	MBLT26	26x1,5	-	-	32
120	MBLT30	30x1,5	-	-	36

VITE CAVA DOPPIA PER OCCHIO GAS DOUBLE BSP BOLT FOR BANJO

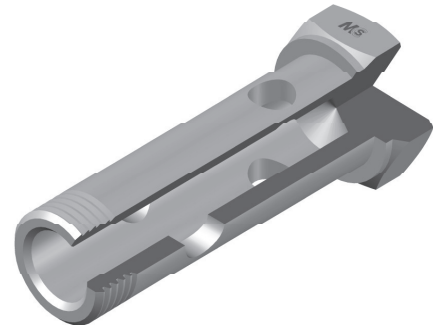
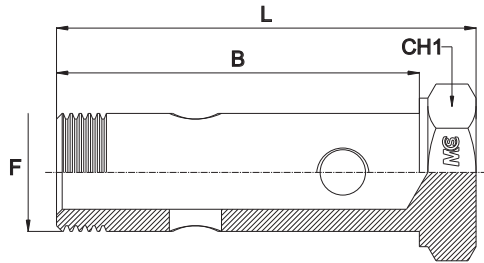

Bar W.P.	Codice Part Number	Filetto Thread	B	L	CH1
300	DBSPBLT04	1/4"	42,0	52,0	19
280	DBSPBLT06	3/8"	50,0	59,0	22
200	DBSPBLT08	1/2"	64,0	74,0	27
	DBSPBLT12	3/4"	-	-	32
120	DBSPBLT16	1"	-	-	41

FEMMINA ORFS

ORFS FEMALE

- ORFS -

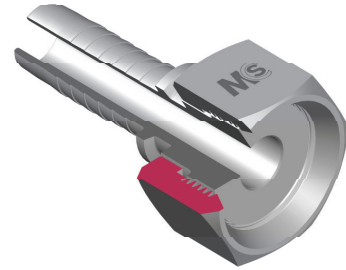
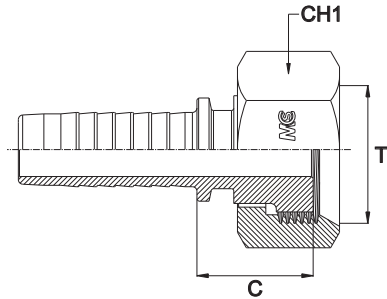

Bar W.P.	Codice Part Number	Filetto Thread	Ø Int. Tubo Inch. Hose I.D.	C Cut - Off	CH1
450	ORFSF0904	9/16"	1/4"	16,7	19
350	ORFSF0905	9/16"	5/16"	16,7	19
450	ORFSF1104	11/16"	1/4"	19,3	22
350	ORFSF1105	11/16"	5/16"	19,3	22
445	ORFSF1106	11/16"	3/8"	19,3	22
	ORFSF1306	13/16"	3/8"	31,5	24
415	ORFSF1308	13/16"	1/2"	-	24
	ORFSF1608	1"	1/2"	20,5	30
	ORFSF1610	1"	5/8"	30,5	30
350	ORFSF1612	1"	3/4"	30,5	30
415	ORFSF1908	1"3/16	1/2"	36,0	36
	ORFSF1912	1"3/16	3/4"	36,0	36
350	ORFSF2312	1"7/16	3/4"	37,0	41
280	ORFSF2316	1"7/16	1"	37,0	41
210	ORFSF2720	1"11/16	1"1/4	37,0	50
185	ORFSF3224	2"	1"1/2	36,5	60

FEMMINA 45° ORFS
45° ORFS FEMALE
- ORFS 45° -

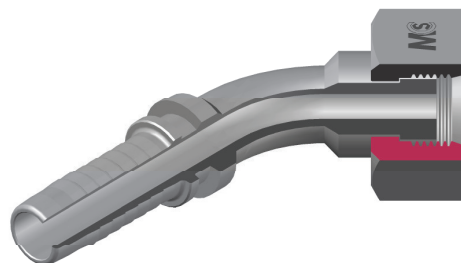
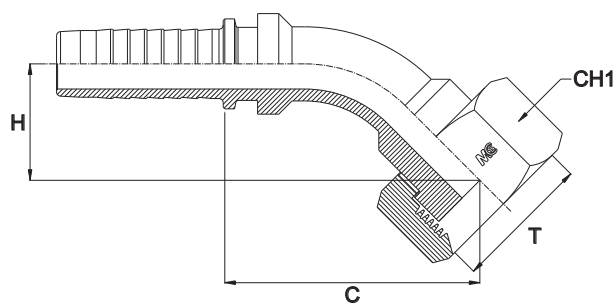

Bar W.P.	Codice Part Number	Filetto Thread	Ø Int. Tubo Inch. Hose I.D.	C Cut - Off	H Drop	CH1
450	45ORFSF0904	9/16"	1/4"	39,5	18,5	19
	45ORFSF1104	11/16"	1/4"	-	-	22
350	45ORFSF1105	11/16"	5/16"	-	-	22
445	45ORFSF1106	11/16"	3/8"	52,5	22,0	22
	45ORFSF1306	13/16"	3/8"	-	-	24
415	45ORFSF1308	13/16"	1/2"	-	-	24
	45ORFSF1608	1"	1/2"	-	-	30
350	45ORFSF1610	1"	5/8"	-	-	30
	45ORFSF1912	1"3/16	3/4"	86,0	32,5	36
	45ORFSF2312	1"7/16	3/4"	-	-	41
280	45ORFSF2316	1"7/16	1"	108,0	42,0	41
210	45ORFSF2720	1"11/16	1"1/4	-	-	50
185	45ORFSF3224	2"	1"1/2	-	-	60

FEMMINA 90° ORFS
90° ORFS FEMALE
- ORFS 90° -

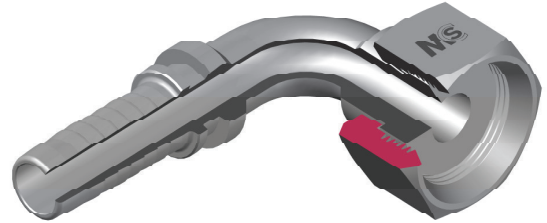
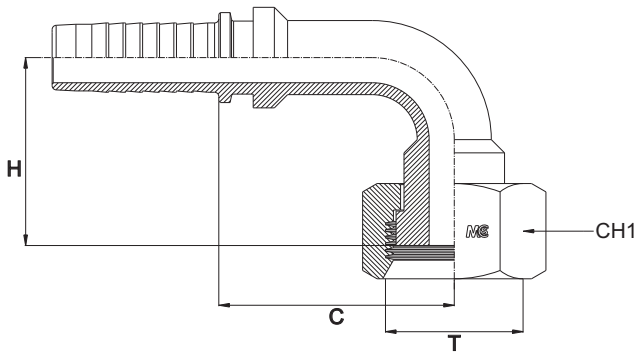

Bar W.P.	Codice Part Number	Filetto Thread	Ø Int. Tubo Inch. Hose I.D.	C Cut - Off	H Drop	CH1
450	90ORFSF0904	9/16"	1/4"	21,5	28,5	19
350	90ORFSF0905	9/16"	5/16"	24,5	25,5	19
450	90ORFSF1104	11/16"	1/4"	37,0	36,8	22
350	90ORFSF1105	11/16"	5/16"	-	-	22
445	90ORFSF1106	11/16"	3/8"	34,0	37,7	22
	90ORFSF1306	13/16"	3/8"	-	-	24
415	90ORFSF1308	13/16"	1/2"	-	-	24
	90ORFSF1608	1"	1/2"	-	-	30
350	90ORFSF1610	1"	5/8"	46,0	49,5	30
	90ORFSF1910	1"3/16	5/8"	-	-	36
	90ORFSF1912	1"3/16	3/4"	53,5	60,5	36
	90ORFSF2312	1"7/16	3/4"	-	-	41
280	90ORFSF2316	1"7/16	1"	64,5	83,0	41
210	90ORFSF2720	1"11/16	1"1/4	81,0	97,5	50
185	90ORFSF3224	2"	1"1/2	-	-	60

MASCHIO ORFS
ORFS MALE
- ORFS -

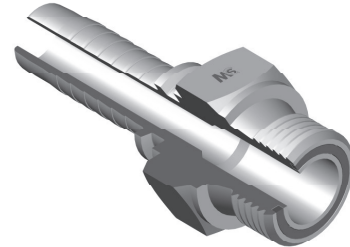
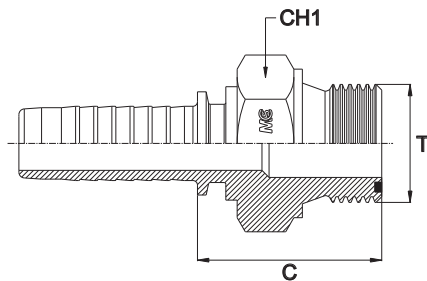

Bar W.P.	Codice Part Number	Filetto Thread	Ø Int. Tubo Inch. Hose I.D.	C Cut - Off	CH1
450	ORFSM0904	9/16"	1/4"	23,5	17
350	ORFSM1105	11/16"	5/16"	27,0	19
445	ORFSM1106	11/16"	3/8"	27,0	19
415	ORFSM1308	13/16"	1/2"	29,0	22
350	ORFSM1610	1"	5/8"	32,5	27
	ORFSM1912	1"3/16	3/4"	36,5	32
280	ORFSM2316	1"7/16	1"	40,5	41
210	ORFSM2720	1"11/16	1"1/4	41,5	46
185	ORFSM3224	2"	1"1/2	-	55

**GHIERA R1 PER TUBO:
R1 FERRULE FOR:
SAE 100 R1AT (EN 853 1SN) - SAE 100 R1A - EN 857 1SC - EN 854 2TE
HOSE TYPE**

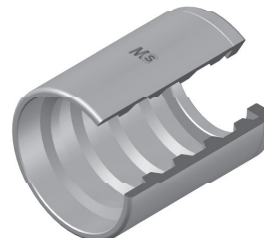
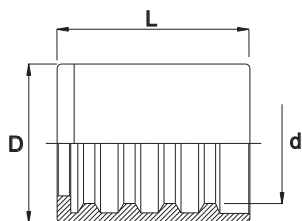

Codice Part Number	Ø Int. Tubo Inch. Hose I.D.	D	d	L
FR103	3/16"	19,0	12,8	29,5
FR104	1/4"	20,0	14,0	30,0
FR105	5/16"	22,0	16,0	30,0
FR106	3/8"	24,0	17,6	32,5
FR108	1/2"	28,0	21,2	34,0
FR110	5/8"	32,0	24,9	40,0
FR112	3/4"	35,0	28,7	42,0
FR116	1"	45,0	37,0	48,0
FR120	1" 1/4	55,0	44,6	56,0
FR124	1" 1/2	60,0	51,2	63,0
FR132	2"	76,2	64,6	76,0
FR140*	2" 1/2	87,0	77,8	76,0
FR148*	3"	102,0	92,0	76,0

* Solo per tubi EN857-1SC / EN857-2SC
Only for EN857-1SC / EN857-2SC hoses

M.C.S. HYDRAULICS

Presenta la nuova ghiera per tubo R1, che ha sostituito le precedenti due versioni FR1T (per tubo SAE 100 R1AT) e FR1A (per tubo SAE 100 R1A); questa nuova ghiera può inoltre essere utilizzata su tubo 1SC e 2TE.

M.C.S. HYDRAULICS

Presents the new ferrule for hose R1 which replaces the previous FR1T (for hose SAE 100 R1AT) and FR1A (for hose SAE 100 R1A); this ferrule can also be used with 1SC and 2TE hoses.

**Corretto Impiego Della FR1 :
FR1 Correct Usage :**

Tubo Hose Type	Skive	No Skive
R1AT		No Skive
1SC		No Skive
2TE		No Skive
R1A	Skive	

OneGGTM EV0

Like no other

*Immagina di poter utilizzare un'unica boccola...
Imagine a single ferrule for all your needs...*

GHIERA OneGGTM PER:

OneGGTM FERRULE FOR:

**SAE 100 R1AT (EN 853 1SN) - SAE 100 R2AT (EN 853 2SN)
EN 857 1SC - HOSE TYPE - SAE 100 R16S (EN 857 2SC)
EN 856 4SP (ISO 3862-1 4SP) - EN 856 4SH (ISO 3862-1 4SH)
SAE 100 R12 (EN 856 R12) - SAE 100 R13 (EN 856 R13)
SAE 100 R15 (ISO 3862-1 R15)
alfabiotech 4000-5000-6000 Compact Hose (ISO 18752)**

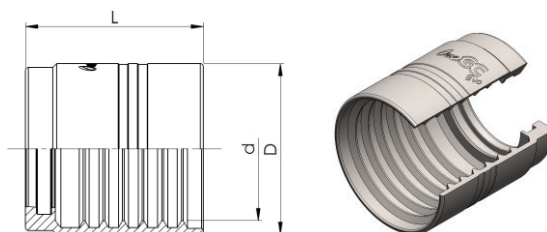

Codice Part Number	Ø Int. Tubo Inch. Hose I.D.	D	d	L
FR2T03*	3/16"	20,0	14,4	29,5
OneGG TM 04	1/4"	22,0	16,0	30,0
OneGG TM 05	5/16"	24,0	17,5	32,0
OneGG TM 06	3/8"	26,0	19,6	32,0
OneGG TM 08	1/2"	30,0	23,0	34,0
OneGG TM 10	5/8"	33,0	26,1	38,0
OneGG TM 12	3/4"	38,0	30,2	42,0
OneGG TM 16	1"	46,0	38,7	48,0
OneGG TM 20	1"1/4	60,0	49,0	56,0
OneGG TM 24	1"1/2	65,0	55,5	63,0
OneGG TM 32	2"	80,0	68,5	74,0



BREVETTO INDUSTRIALE
N° 0001383708



* Solo per tubi EN853-2SN / EN857-2SC
Only for EN853-2SN / EN857-2SC hoses

Corretto Impiego della OneGGTM
OneGGTM Correct Usage :

Tubo Hose Type	Skive	No Skive
R1AT		No Skive
R2AT		No Skive
1SC		No Skive
2SC		No Skive
4SP	Skive	
4SH	Skive	
R12	Skive	
R13	Skive	
R15	Skive	
alfabiotech	Skive	

**GHIERA R7 PER TUBO SAE 100 R7 (EN 855 R7) - SAE 100 R8 (EN 855 R8)
 SAE 100 R6 (EN 854 1TE) - SAE 100 R1 (MTH1 SERIES)
 R7 FERRULE FOR HOSE SAE 100 R7 (EN 855 R7) - SAE 100 R8 (EN 855 R8)
 SAE 100 R6 (EN 854 1TE) - SAE 100 R1 (MTH1 SERIES)**

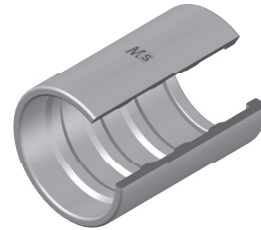
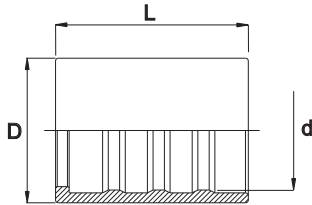

Codice Part Number	Ø Int. Tubo Inch. Hose I.D.	D	d	L
FR702	1/8"	12,0	9,0	24,0
FR703	3/16"	14,0	10,7	26,0
FR704	1/4"	17,0	13,6	29,5
FR705	5/16"	19,0	15,2	30,0
FR706	3/8"	21,0	16,8	31,0
FR708	1/2"	25,5	21,0	34,0
FR710	5/8"	28,5	24,0	37,0
FR712	3/4"	32,0	27,5	42,0
FR716	1"	43,5	36,0	48,0

**GHIERA R3 PER TUBO SAE 100 R3 (EN 854 R3) - EN 854 3TE - SAE 100 R4
R3 FERRULE FOR HOSE SAE 100 R3 (EN 854 R3) - EN 854 3TE - SAE 100 R4**

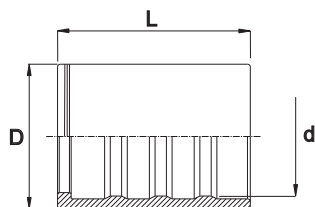

Codice Part Number	Ø Int. Tubo Inch. Hose I.D.	D	d	L
FR3TE03	3/16"	*	*	*
FR3TE04	1/4"	19,0	15,3	29,5
FR3TE05	5/16"	22,0	18,5	30,0
FR3TE06	3/8"	24,0	19,9	31,0
FR3TE08	1/2"	28,5	25,0	34,0
FR3TE10	5/8"	32,0	28,0	37,0
FR3TE12	3/4"	38,0	32,6	42,0
FR3TE16	1"	46,0	39,5	48,0
FR3TE20	1" 1/4	52,0	46,0	56,0
FR3TE24	1" 1/2	60,0	53,0	63,0
FR3TE32	2"	76,0	65,0	76,0

GHIERA PER TUBO TEFLON LISCIO - PICCOLO-MEDIO-GROSSO SPESSORE FERRULE FOR SMOOTH PTFE HOSE - LIGHT-MEDIUM-HEAVY WALL

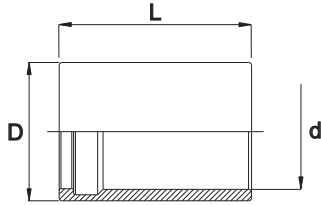

Codice Part Number	Ø Int. Tubo Inch. Hose I.D.	D	d	L
FRTE02	1/8"	12,0	8,0	24,0
FRTE03	3/16"	12,0	9,1	25,5
FRTE04	1/4"	14,0	11,3	29,5
FRTE05	5/16"	17,0	13,5	32,0
FRTE06	3/8"	19,0	15,7	32,0
FRTE08	1/2"	23,0	19,2	32,0
FRTE10	5/8"	27,0	21,6	37,0
FRTE12	3/4"	30,0	25,2	43,0
FRTE16	1"	37,0	32,0	48,0

GHIERA PER TUBO TEFLON CORRUGATO FERRULE FOR CONVOLUTED PTFE HOSE

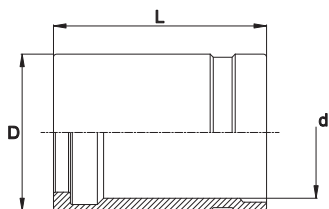

Codice Part Number	Ø Int. Tubo Inch. Hose I.D.	D	d	L
FRTC04	1/4"	16,0	12,5	29,5
FRTC05	5/16"	17,0	13,0	30,0
FRTC06	3/8"	21,5	17,8	31,0
FRTC08	1/2"	25,0	21,0	34,0
FRTC10	5/8"	29,0	24,5	37,0
FRTC12	3/4"	34,0	29,0	42,0
FRTC16	1"	40,0	34,8	48,0
FRTC20	1" 1/4	48,0	42,0	56,0
FRTC24	1" 1/2	55,0	49,0	63,0
FRTC32	2"	69,0	63,0	74,0

* NB : Per il tubo corrugato si raccomanda di avvolgere il raccordo nella sua lunghezza con 2 giri di nastro PTFE prima dell'inserimento nel tubo.

NOTE : For the CONVOLUTED Hoses, we suggest to wrap up the fitting for its length with 2 turns of PTFE Ribbon before the insertion into the hose.