

PASSAPARETE MASCHIO CON DADO

Filetto Gas Cilindrico

BULKHEAD UNION (WITH NUT)

Thread BSP Parallel

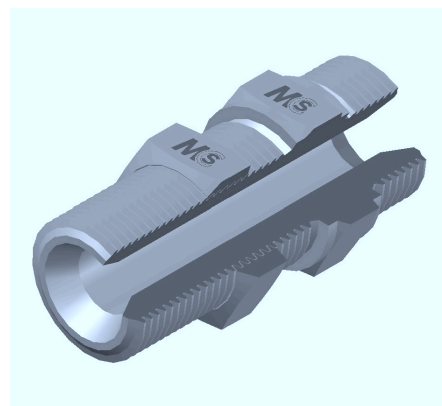
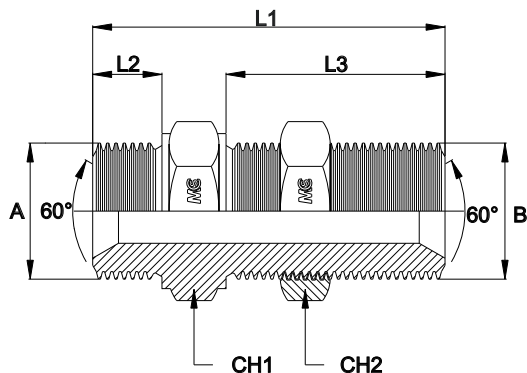

Bar W.P.	Codice Part Number	A	B	L1	L2	L3	CH1	CH2
400	BBSPMA02	1/8"	1/8"	44,0	8,0	27,0	14	14
	BBSPMA04	1/4"	1/4"	50,0	11,0	28,0	19	19
	BBSPMA06	3/8"	3/8"	54,0	12,0	31,0	22	22
350	BBSPMA08	1/2"	1/2"	61,5	14,0	35,0	27	27
	BBSPMA10	5/8"	5/8"	66,0	16,0	38,0	30	30
315	BBSPMA12	3/4"	3/4"	66,0	16,0	38,0	32	32
250	BBSPMA16	1"	1"	72,0	19,0	41,0	41	41
220	BBSPMA20	1" 1/4	1" 1/4	79,0	20,0	45,0	50	50
170	BBSPMA24	1" 1/2	1" 1/2	86,7	20,0	52,5	55	55
125	BBSPMA32	2"	2"	93,0	24,5	52,5	70	70

PASSAPARETE A 90° MASCHIO CON DADO

Filetto Gas Cilindrico

BULKHEAD MALE ELBOW (WITH NUT)

Thread BSP Parallel

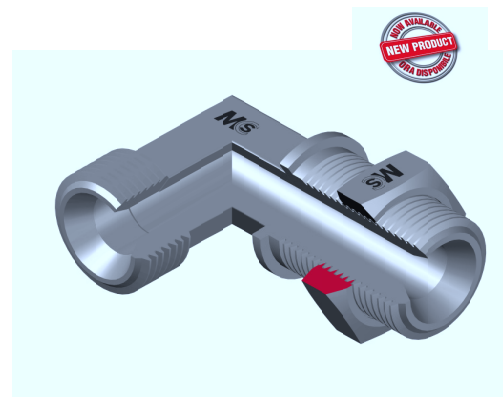
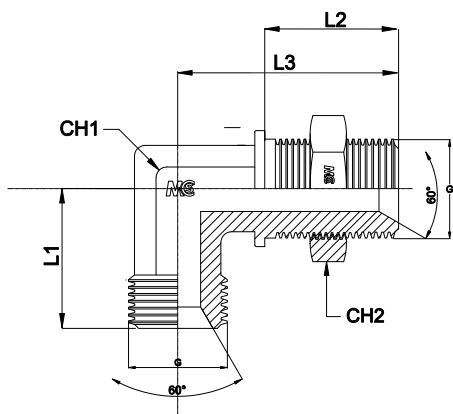

Bar W.P.	Codice Part Number	A	B	L1	L2	L3	CH1	CH2
400	LBBSPMA02	1/8"	1/8"	21,0	28,0	41,0	12	14
	LBBSPMA04	1/4"	1/4"	26,0	28,0	45,0	14	19
	LBBSPMA06	3/8"	3/8"	29,0	32,0	52,0	19	22
350	LBBSPMA08	1/2"	1/2"	34,0	35,0	58,0	24	27
	LBBSPMA10	5/8"	5/8"	38,0	35,0	58,0	27	30
315	LBBSPMA12	3/4"	3/4"	41,0	38,0	65,0	27	32
250	LBBSPMA16	1"	1"	45,0	41,0	71,0	36	41
220	LBBSPMA20	1" 1/4	1" 1/4	52,0	44,0	79,0	41	50
170	LBBSPMA24	1" 1/2	1" 1/2	59,0	46,0	90,5	50	55